



Kroeplin
Längenmesstechnik

שטרנג אבי
ציוד טכני בע"מ

יבואנים בלעדיים בישראל
שירות תיקון עם חלפים מקוריים

רח' המרכבה 19,

ת.ד. 1730

א.ת. חולון 5811701

טל: 03-5599222

פקס: 03-5598777

דוא"ל: office@streng.co.il

אתר: www.streng.co.il

Application area

- n Mechanical engineering
- n Automobile industry
- n Aerospace industry
- n Wire manufacturers:
Diameter determination of continuous wires
- n Glass industry: Measurement of wall thickness
in hard-to-access places
- n Dental laboratories: Measurement of tooth
crown thicknesses
- n Aerosol and packaging industry:
Measurement of aerosol cans
- n Foundries: Measurement of cast wall thicknesses
- n Key manufacturers: Measurement of milled
notches of keys
- n Foamed material industry: Measurements
of foamed material thicknesses
- n Tubemanufacturers: Internal and external measurements,
also of extremely wide tubes
- n Ceramic industry: Safe and simple determination
of contraction due to baking and drying.
- n Gun clubs: Checking of the admissible thickness
of shooting jackets
- n Medical institutes: Skin fold and joint measurement in
human and animal subjects
- n Special designs: Your measuring task is among them

Precision and continuity

Ever since its foundation in 1883 Kroeplin have been involved in development and production of handy reliable and precise gauges for the measurement of lengths and thicknesses, especially for the metalworking industry. Thus the quick test system was created, which was the basis for all further innovations and also for the electronic dial indicators.



DIN EN ISO9001:2008

Experience is the solid foundation for quality. Careful observation and analysis of the market, flexible realization of requirements, convincing measuring concepts - that is the philosophy that makes Kroeplin successful. Today like before, for more than 125 years.

Features

- Certificate of quality
- Reliable repeatability
- Scales are well arranged and easy to read
- Scale interval from 0,005mm up
- Tolerance marks easy to read
- All mechanical gauges are also available in "INCH"
- The electronic gauges can be switched over to "INCH"
- Measuring contacts are mainly made of carbide
- Electronic gauges with analog / digital display for better reading
- Mitutoyo interface
- USB interface
- Ergonomically designed
- Measuring programs and contacts for different applications
- Absolute and relative measurement
- Red / Green LED for tolerance measurement
- Special solutions possible
- Stand holding unit for serial measurement of small parts
- Convincing price for convincing performance

Detailed information and data sheets for all gauges are available on our webpage www.kroeplin.com

Contents

Internal measurement	
Application range up to 60mm	4-5
Application range up to 120mm	6-7
Application range exceeding 120mm	8-9
Internal comparison measurement	10-11
Internal measurement with 3-point contact	12
Internal measurement for blind holes	13
External measurement	
Application range up to 30mm	14-15
Application range up to 200mm	16-17
Tube wall measurement	
Application range up to 100mm	18-19
Measurement of foamed material and foils	
Application range up to 100mm	20-21
Accessories / Interfaces	22
Special gauges / Definitions	23

Subject to technical alterations

NEW!

Instruments with 3-point contact for easier centering



Measuring contacts

- n easy handling
- n high repeatability
- n measuring programs and contacts for different applications
- n suitable for workshop use
- n IP 67
- n Interface (Digimatic, USB, U-WAVE®)
- n mm/inch switch

- n fast reading
- n accurate measurement
- n precise measuring results

NEW!

Ergonomically designed with new IP classification

The gauges provide a digital/analog display for better reading. The quicktest gauges include custom designed test programs, measuring contacts, absolute and relative measuring programs and red/green display for tolerance measurement.



The established and proven generation of Quicktests

mechanical



- n IP 65
- n optimized measuring force
- n accurate measurement
- n ergonomically designed

electronic



- n IP 67
- n optimized measuring force
- n digital display with analog bar
- n ergonomically designed
- n Interfaces (USB, DIGIMATIC or U-WAVE) available on request

Internal Measurement

Application range up to 60 mm



G102



H105



G210



H210



G330

Type	Measuring span Mes [mm]	Measuring range Meb [mm]	Range of indication AzB [mm]	Scale interval Skw [mm]	Permissible errors G [mm]	Repeatability limit r [mm]	Measuring force min. [N]	Measuring force max. [N]	Weight [g]	Protection class	Measuring contact movable Hb [mm]	Measuring contact fixed Hf [mm]	Type of measuring contact [mm]	Groovedepth A max. [mm]	Groove width B min. [mm]	Measuring depth L max. [mm]	Picture	Electronic E Mechanical M	Wooden box
G102	10	2,5 - 12,5	2,4 - 12,8	0,005	0,015	0,005	0,8	1,2	225	IP67	0,9	0,9	Chisel R 0,1	0,7	0,5	12	[1]	E	1732-45
H102	10	2,5 - 12,5	2,4 - 12,8	0,005	0,015	0,005	0,8	1,2	155	IP65	0,9	0,9	Chisel R 0,1	0,7	0,5	12	[1]	M	1732-45
G105	10	5 - 15	4,7 - 15,3	0,005	0,015	0,005	0,8	1,2	230	IP67	2,5	2,5	Ball Ø0,6	2,3	0,8	35	[2]	E	1732-45
H105	10	5 - 15	4,7 - 15,3	0,005	0,015	0,005	0,8	1,2	160	IP65	2,5	2,5	Ball Ø0,6	2,3	0,8	35	[2]	M	1732-45
G210	20	10 - 30	9,5 - 30,5	0,01	0,03	0,01	1,1	1,6	250	IP67	5,3	5,3	Ball Ø1	5,2	1,2	85	[2]	E	1732-45
H210	20	10 - 30	9,5 - 30,5	0,01	0,03	0,01	1,1	1,6	180	IP65	5,3	5,3	Ball Ø1	5,2	1,2	85	[2]	M	1732-45
G220	20	20 - 40	19,5 - 40,5	0,01	0,03	0,01	1,1	1,6	250	IP67	7,3	7,3	Ball Ø1	7,0	1,2	85	[4]	E	1732-45
H220	20	20 - 40	19,5 - 40,5	0,01	0,03	0,01	1,1	1,6	180	IP65	7,3	7,3	Ball Ø1	7,0	1,2	85	[4]	M	1732-45
G230	20	30 - 50	29,5 - 50,5	0,01	0,03	0,01	1,1	1,6	255	IP67	7,3	7,3	Ball Ø1	7,0	1,2	85	[4]	E	1732-45
H230	20	30 - 50	29,5 - 50,5	0,01	0,03	0,01	1,1	1,6	185	IP65	7,3	7,3	Ball Ø1	7,0	1,2	85	[4]	M	1732-45
G240	20	40 - 60	39,5 - 60,5	0,01	0,03	0,01	1,1	1,6	265	IP67	8,5	8,5	Ball Ø1	8,3	1,2	85	[5]	E	1732-45
H240	20	40 - 60	39,5 - 60,5	0,01	0,03	0,01	1,1	1,6	195	IP65	8,5	8,5	Ball Ø1	8,3	1,2	85	[5]	M	1732-45
G313	30	13 - 43	12,5 - 43,5	0,02	0,04	0,02	1,2	1,7	360	IP67	5,7	5,7	Ball Ø1,3	5,7	1,6	127	[2]	E	1732-51
G330	30	30 - 60	29,5 - 60,5	0,02	0,04	0,02	1,2	1,7	370	IP67	6,5	6,5	Ball Ø1,5	6,2	1,8	132	[5]	E	1732-51

Measuring contacts

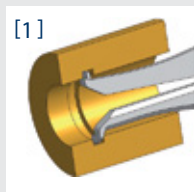

[1] Chisel R 0,1 mm

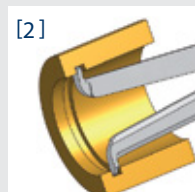

[2] Ball Ø 0,6 mm
Ball Ø 1,0 mm
Ball Ø 1,3 mm

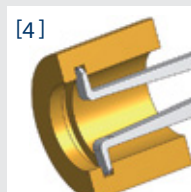

[4] Ball Ø 1,0 mm



[5] Ball Ø 1,0 mm
Ball Ø 1,5 mm
Ball Ø 2,0 mm

Measuring capacity

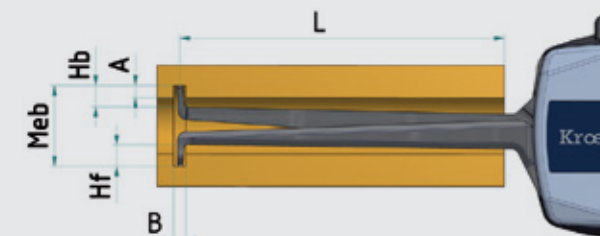

Meb Measuring range

A Groove depth

B Groove width

Hb Measuring contact movable

Hf Measuring contact fixed

L Measuring depth

Internal Measurement

Application range up to 120 mm



G240



H240



G415

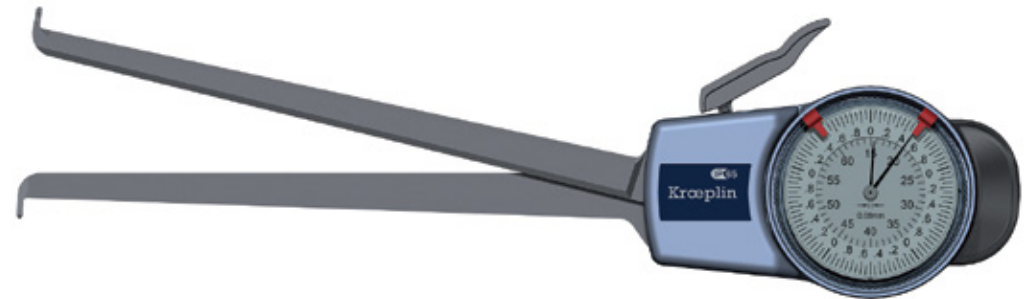

H415



G370

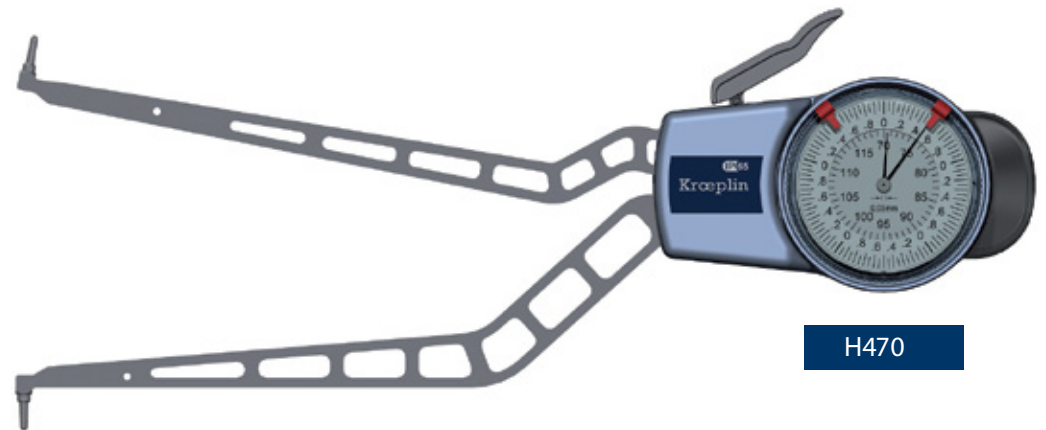

H470

Type	Measuring span Mes [mm]	Measuring range Meb [mm]	Range of indication AzB [mm]	Scale interval Skw [mm]	Permissible errors G [mm]	Repeatability limit r [mm]	Measuring force min. [N]	Measuring force max. [N]	Weight [g]	Protection class	Measuring contact movable Hb [mm]	Measuring contact fixed Hf [mm]	Type of measuring contact [mm]	Groovedepth A max. [mm]	Groove width B min. [mm]	Measuring depth L max. [mm]	Picture	Electronic E Mechanical M	Wooden box
G250	20	50 - 70	49,5 - 70,5	0,01	0,03	0,01	1,1	1,6	265	IP67	8,5	8,5	Ball Ø1	8,3	1,2	85	[5]	E	1732-45
H250	20	50 - 70	49,5 - 70,5	0,01	0,03	0,01	1,1	1,6	195	IP65	8,5	8,5	Ball Ø1	8,3	1,2	85	[5]	M	1732-45
G260	20	60 - 80	59,5 - 80,5	0,01	0,03	0,01	1,1	1,6	270	IP67	8,5	8,5	Ball Ø1	8,3	1,2	85	[5]	E	1732-45
H260	20	60 - 80	59,5 - 80,5	0,01	0,03	0,01	1,1	1,6	200	IP65	8,5	8,5	Ball Ø1	8,3	1,2	85	[5]	M	1732-45
G270	20	70 - 90	69,5 - 90,5	0,01	0,03	0,01	1,1	1,6	270	IP67	8,5	8,5	Ball Ø1	8,3	1,2	85	[5]	E	1732-45
H270	20	70 - 90	69,5 - 90,5	0,01	0,03	0,01	1,1	1,6	200	IP65	8,5	8,5	Ball Ø1	8,3	1,2	85	[5]	M	1732-45
G280	20	80 - 100	79,5 - 100,5	0,01	0,03	0,01	1,1	1,6	270	IP67	8,5	8,5	Ball Ø1	8,3	1,2	85	[5]	E	1732-45
H280	20	80 - 100	79,5 - 100,5	0,01	0,03	0,01	1,1	1,6	200	IP65	8,5	8,5	Ball Ø1	8,3	1,2	85	[5]	M	1732-45
G350	30	50 - 80	49,5 - 80,5	0,02	0,04	0,02	1,2	1,7	370	IP67	8,5	8,5	Ball Ø2	8,3	2,4	132	[5]	E	1732-51
G370	30	70 - 100	69,5 - 100,5	0,02	0,04	0,02	1,2	1,7	375	IP67	8,5	8,5	Ball Ø2	8,3	2,4	132	[5]	E	1732-51
G390	30	90 - 120	89,5 - 120,5	0,02	0,04	0,02	1,2	1,7	380	IP67	8,5	8,5	Ball Ø2	8,3	2,4	132	[3]	E	1732-51
G415	50	15 - 65	14,5 - 65,5	0,02	0,06	0,04	1,0	1,8	415	IP67	6,0	6,0	Ball Ø1,5	5,5	1,9	188	[3]	E	1732-51
H415	50	15 - 65	14,5 - 65,5	0,05	0,05	0,025	0,9	1,9	355	IP65	6,0	6,0	Ball Ø1,5	5,5	1,9	188	[5]	M	1732-51
G440	50	40 - 90	39,5 - 90,5	0,02	0,06	0,04	1,0	1,8	420	IP67	8,5	8,5	Ball Ø2	8,3	2,4	192	[5]	E	1732-51
H440	50	40 - 90	39,5 - 90,5	0,05	0,05	0,025	0,9	1,9	370	IP65	8,5	8,5	Ball Ø2	8,3	2,4	192	[5]	M	1732-51
G470	50	70 - 120	69,5 - 120,5	0,02	0,06	0,04	1,0	1,8	420	IP67	8,5	8,5	Ball Ø2	8,3	2,4	192	[5]	E	1732-51
H470	50	70 - 120	69,5 - 120,5	0,05	0,05	0,025	0,9	1,9	370	IP65	8,5	8,5	Ball Ø2	8,3	2,4	192	[5]	M	1732-51

Measuring contacts

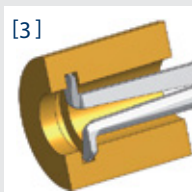

[3]
Ball Ø 1,0 mm
Ball Ø 1,5 mm



[5]
Ball Ø 1,0 mm
Ball Ø 2,0 mm

Measuring capacity

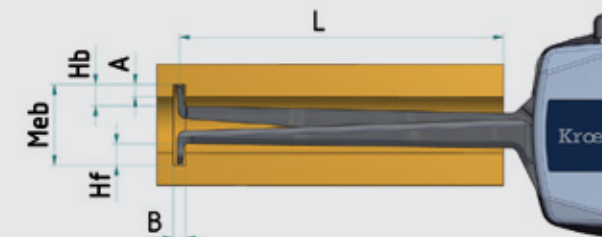

Meb Measuring range
A Groove depth
B Groove width
Hb Measuring contact movable
Hf Measuring contact fixed
L Measuring depth

Internal Measurement

Application range up to 120 mm

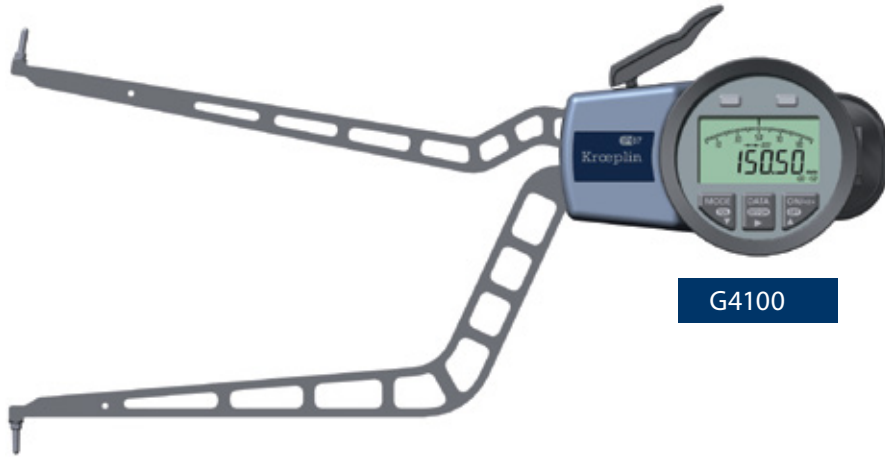

G410

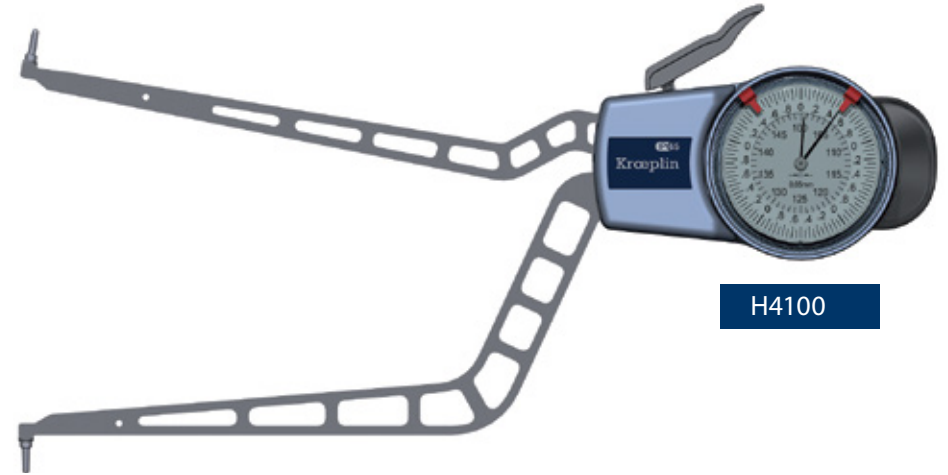

H410



G850



H870



ID80200

Type	Measuring span Mes [mm]	Measuring range Meb [mm]	Range of indication AzB [mm]	Scale interval Skw [mm]	Permissible errors G [mm]	Repeatability limit r [mm]	Measuring force min. [N]	Measuring force max. [N]	Weight [g]	Protection class	Measuring contact movable Hb [mm]	Measuring contact fixed Hf [mm]	Type of measuring contact [mm]	Groovedepth A max. [mm]	Groove width B min. [mm]	Measuring depth L max. [mm]	Picture	Electronic E Mechanical M	Wooden box
G4100	50	100 - 150	99,5 - 150,5	0,02	0,06	0,04	1,0	1,8	425	IP67	8,5	8,5	Ball Ø2	8,3	2,4	192	[5]	E	1732-51
H4100	50	100 - 150	99,5 - 150,5	0,05	0,05	0,025	0,9	1,9	385	IP65	8,5	8,5	Ball Ø2	8,3	2,4	192	[5]	M	1732-51
G4130	50	130 - 180	129,5 - 180,5	0,02	0,06	0,04	1,0	1,8	430	IP67	8,5	8,5	Ball Ø2	8,3	2,4	192	[5]	E	HK
H4130	50	130 - 180	129,5 - 180,5	0,05	0,05	0,025	0,9	1,9	390	IP65	8,5	8,5	Ball Ø2	8,3	2,4	192	[5]	M	HK
G4150	50	150 - 200	149,5 - 200,5	0,02	0,06	0,04	1,0	1,8	435	IP67	8,5	8,5	Ball Ø2	8,3	2,4	192	[5]	E	HK
H4150	50	150 - 200	149,5 - 200,5	0,05	0,05	0,025	0,9	1,9	395	IP65	8,5	8,5	Ball Ø2	8,3	2,4	192	[5]	M	HK
G850	100	50 - 150	49,5 - 150,5	0,05	0,15	0,1	0,8	2,0	650	IP67	4,0	4,0	Ball Ø5	3,0	5,5	395	[18]	E	HK
H850	100	50 - 150	49,5 - 150,5	0,1	0,15	0,1	0,8	2,0	590	IP65	4,0	4,0	Ball Ø5	3,0	5,5	395	[18]	M	HK
G870	100	70 - 170	69,5 - 170,5	0,05	0,15	0,1	0,8	2,0	650	IP67	14,0	14,0	Ball Ø5	13,0	5,5	395	[19]	E	HK
H870	100	70 - 170	69,5 - 170,5	0,1	0,15	0,1	0,8	2,0	590	IP65	14,0	14,0	Ball Ø5	13,0	5,5	395	[19]	M	HK
ID6080	100	80 - 180	79,5 - 180,5	0,1	0,25	0,1	1,5	2,5	1600	-	12,0	12,0	Ball Ø5	11,0	5,5	535	[19]	M	HK
ID60150	100	150 - 250	149,5 - 250,5	0,1	0,3	0,1	1,5	2,5	1600	-	32,0	32,0	Ball Ø5	31,0	5,5	535	[19]	M	HK
ID60220	100	220 - 320	219,5 - 320,5	0,1	0,3	0,1	1,5	2,5	1700	-	32,0	32,0	Ball Ø5	31,0	5,5	535	[19]	M	HK
ID80200	200	200 - 400	199,5 - 400,5	0,2	0,4	0,2	1,0	2,0	2200	-	29,0	29,0	Hemisphere SR20	28,0	21,0	735	[20]	M	HK

Measuring contacts



Ball Ø 2,0 mm



Ball Ø 5,0 mm



Ball Ø 5,0 mm



Hemisphere
SR 20 mm

Measuring capacity

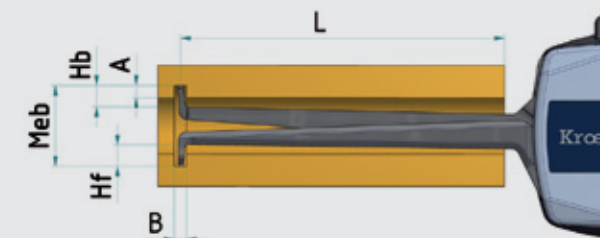

Meb Measuring range

A Groove depth

B Groove width

Hb Measuring contact movable

Hf Measuring contact fixed

L Measuring depth

Internal Comparison Measurement

Application range from 50 mm to 430 mm

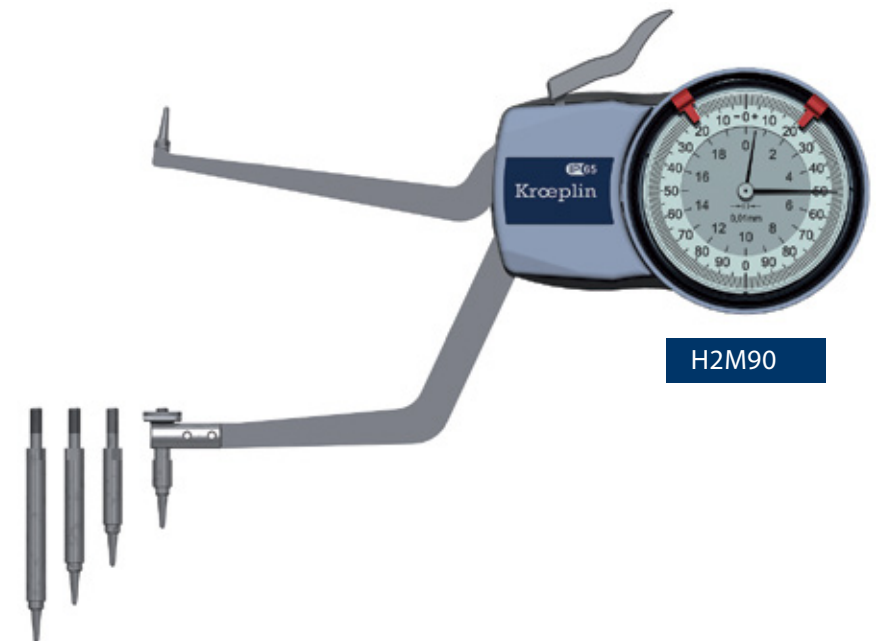
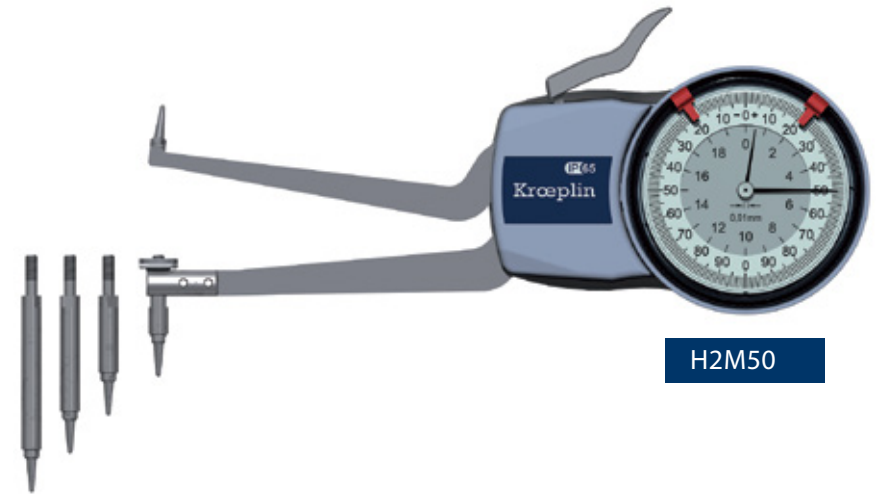
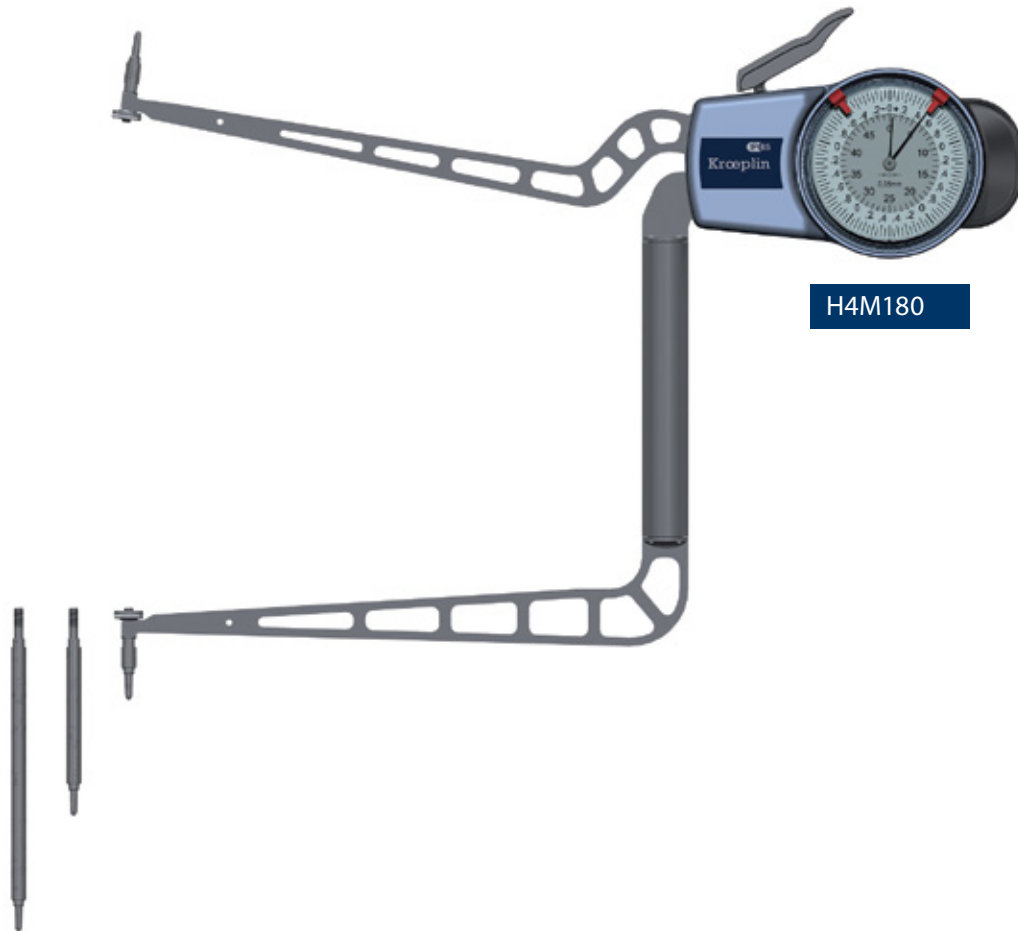

	Measuring span Mes	Measuring range Meb	Range of indication Azb	Scale interval Skw	Permissible errors G	Repeatability limit r	Measuring force min.	Measuring force max.	Weight	Protection class	Measuring contact movable Hb	Measuring contact fixed Hf	Type of measuring contact	Groovedepth A max.	Groove width B min.	Measuring depth L max.	Picture	Electronic E Mechanical M	Wooden box
Type	[mm]	[mm]	[mm]	[mm]	[mm]	[mm]	[N]	[N]	[g]		[mm]	[mm]	[mm]	[mm]	[mm]	[mm]			
H2M50	20	50 - 100	49,5 - 100,5	0,01	0,03	0,015	1,1	1,6	220	IP65	12,0	variable	Ball Ø1	8,3	1,2	85	[5]	M	HK
H2M90	20	90 - 140	89,5 - 140,5	0,01	0,03	0,015	1,1	1,6	230	IP65	12,0	variable	Ball Ø1	8,3	1,2	85	[5]	M	HK
H2M130	20	130 - 180	129,5 - 180,5	0,01	0,03	0,015	1,1	1,6	240	IP65	12,0	variable	Ball Ø1	8,3	1,2	85	[5]	M	HK
H4M180	50	180 - 310	179,5 - 310,5	0,05	0,10	0,05	0,9	1,9	420	IP65	21,0	variable	Ball Ø2	8,3	2,2	170	[5]	M	HK
H4M300	50	300 - 430	299,5 - 430,5	0,05	0,15	0,05	0,9	1,9	450	IP65	21,0	variable	Ball Ø2	8,3	2,2	170	[5]	M	HK

Measuring contacts



[5]
Ball Ø 1,0 mm
Ball Ø 2,0 mm

Measuring capacity

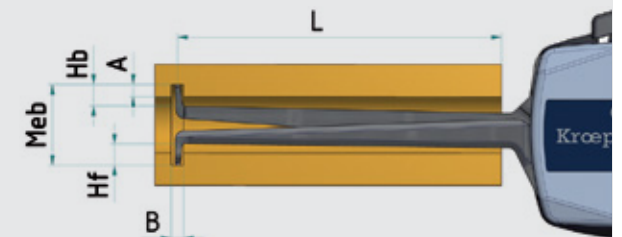

Meb Measuring range
A Groove depth
B Groove width
Hb Measuring contact movable
Hf Measuring contact fixed
L Measuring depth

Internal measurement with 3-point contact

Application range from 7 mm to 105 mm



G210P3

	Measuring span Mes	Measuring range Meb	Range of indication Azb	Numerical interval Zw	Permissible errors G	Repeatability limit r	Measuring force min.	Measuring force max.	Weight	Protection class	Measuring contact movable Hb	Measuring contact movable Hf	Type of measuring contact	Groove depth A max.	Groove width B min.	Measuring depth L max.	Picture	Mechanical M Electronic E	Wooden box
Type	[mm]	[mm]	[mm]	[mm]	[mm]	[mm]	[N]	[N]	[g]		[mm]	[mm]	[mm]	[mm]	[mm]	[mm]			
G107P3	7	7 - 14	6,8 - 14,5	0,002	0,01	0,004	1,0	1,4	230	IP67	2,5	-	Ball Ø0,6	2,2	0,8	34	[1]	E	1732-45
G210P3	10	10 - 20	9,8 - 20,5	0,005	0,02	0,01	1,1	1,6	250	IP67	4,6	-	Ball Ø1	3,5	1,6	75	[2]	E	1732-45
G215P3	15	15 - 30	14,5 - 30,5	0,005	0,02	0,01	1,1	1,6	275	IP67	5,8	-	Ball Ø1	5,0	1,6	77	[2]	E	1732-45
G225P3	20	25 - 45	24,5 - 45,5	0,005	0,02	0,01	1,1	1,6	255	IP67	7,3	-	Ball Ø1	7,0	1,6	84	[3]	E	1732-45
G240P3	20	40 - 60	39,5 - 60,5	0,005	0,02	0,01	1,1	1,6	270	IP67	12,2	-	Ball Ø1	8,0	1,6	84	[3]	E	1732-45
G255P3	20	55 - 75	54,5 - 75,5	0,005	0,02	0,01	1,1	1,6	270	IP67	12,2	-	Ball Ø1	8,0	1,6	84	[3]	E	1732-45
G270P3	20	70 - 90	69,5 - 91	0,005	0,02	0,01	1,1	1,6	275	IP67	12,2	-	Ball Ø1	8,5	1,6	84	[3]	E	1732-45
G285P3	20	85 - 105	84,5 - 106	0,005	0,02	0,01	1,1	1,6	285	IP67	12,2	-	Ball Ø1	9,0	1,6	84	[3]	E	1732-45

Measuring contacts

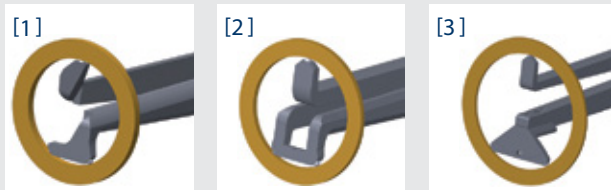

Ball Ø 0,6 mm

Ball Ø 1,0 mm

Ball Ø 1,0 mm

Measuring capacity

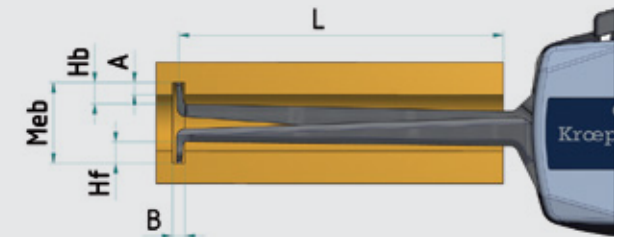

Meb Measuring range

A Groove depth

B Groove width

Hb Measuring contact movable

Hf Measuring contact fixed

L Measuring depth

Internal measurement for blind holes

Application range from 20 mm to 70 mm



Type	Measuring span Mes [mm]	Measuring range Meb [mm]	Range of indication Azb [mm]	Numerical interval Zw [mm]	Permissible errors G [mm]	Repeatability limit r [mm]	Measuring force min. [N]	Measuring force max. [N]	Weight [g]	Protection class	Type of measuring contact [mm]	Measuring contact movable Hb [mm]	Measuring contact movable Hf [mm]	max. Measuring contact thickness [mm]	Measuring depth L max. [mm]	Picture	Mechanical M Electronic E	Wooden box
G2G20	20	20 - 40	19,5 - 40,5	0,01	0,03	0,01	1,1	1,6	250	IP67	Conus SR = 0,2	5,0	5,0	∅ 1,6	85	[13]	E	1732-45
H2G20	20	20 - 40	19,5 - 40,5	0,01	0,03	0,01	1,1	1,6	180	IP65	Conus SR = 0,2	5,0	5,0	∅ 1,6	85	[13]	M	1732-45
G2G30	20	30 - 50	29,5 - 50,5	0,01	0,03	0,01	1,1	1,6	255	IP67	Conus SR = 0,2	5,0	5,0	∅ 1,6	85	[13]	E	1732-45
H2G30	20	30 - 50	29,5 - 50,5	0,01	0,03	0,01	1,1	1,6	185	IP65	Conus SR = 0,2	5,0	5,0	∅ 1,6	85	[13]	M	1732-45
G2G40	20	40 - 60	39,5 - 60,5	0,01	0,03	0,01	1,1	1,6	265	IP67	Conus SR = 0,2	5,0	5,0	∅ 1,6	85	[13]	E	1732-45
H2G40	20	40 - 60	39,5 - 60,5	0,01	0,03	0,01	1,1	1,6	195	IP65	Conus SR = 0,2	5,0	5,0	∅ 1,6	85	[13]	M	1732-45
G2G50	20	50 - 70	49,5 - 70,5	0,01	0,03	0,01	1,1	1,6	265	IP67	Conus SR = 0,2	5,0	5,0	∅ 1,6	85	[13]	E	1732-45
H2G50	20	50 - 70	49,5 - 70,5	0,01	0,03	0,01	1,1	1,6	195	IP65	Conus SR = 0,2	5,0	5,0	∅ 1,6	85	[13]	M	1732-45

Further measuring ranges available on request

Measuring contacts



Conus SR 0,2 mm

Measuring capacity

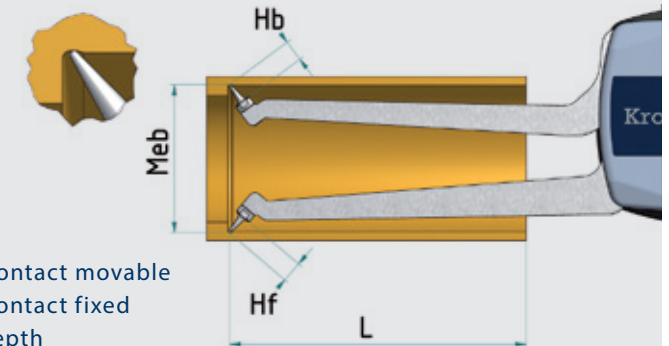

- Hb Measuring contact movable
- Hf Measuring contact fixed
- L Measuring depth

External measurement

Application range up to 30 mm



POCO2K



C110



D110



C220



D220



C330

	Measuring span Mes	Measuring range Meb	Range of indication Azb	Scale interval Skw	Permissible errors G	Repeatability limit r	Measuring force min.	Measuring force max.	Weight	Protection class	Measuring contact movable Hb	Measuring contact fixed Hf	Type of measuring contact	Measuring depth L max.	Picture	Electronic E Mechanical M	Wooden box
Type	[mm]	[mm]	[mm]	[mm]	[mm]	[mm]	[N]	[N]	[g]		[mm]	[mm]	[mm]	[mm]			
POCO 2K	10	0 - 10	0 - >10	0,1	0,1	0,05	0,3	1,3	40	-	5	5	Ball Ø5	36	[23]	M	1732-01
POCO 2N	10	0 - 10	0 - >10	0,1	0,1	0,05	0,3	1,3	40	-	3,5	3,5	Needle Ø 0,75	36	[24]	M	1732-01
POCO 2F	10	0 - 10	0 - >10	0,1	0,1	0,05	0,3	1,3	40	-	4,5	4,5	Sn-R 0,5 / F Ø3,5	36	[25]	M	1732-01
C110	10	0 - 10	0 - 10,5	0,005	0,015	0,005	0,8	1,2	240	IP67	19,1	18,6	Ball Ø1,5	35	[6]	E	1732-45
D110	10	0 - 10	0 - 10,5	0,005	0,015	0,005	0,8	1,2	170	IP65	19,1	18,6	Ball Ø1,5	35	[6]	M	1732-45
C110S	10	0 - 10	0 - 10,5	0,005	0,015	0,005	0,8	1,2	240	IP67	18,8	18,5	Chisel R 0,4	35	[7]	E	1732-45
D110S	10	0 - 10	0 - 10,5	0,005	0,015	0,005	0,8	1,2	170	IP65	18,8	18,5	Chisel R 0,4	35	[7]	M	1732-45
C220	20	0 - 20	0 - 20,5	0,01	0,03	0,01	1,1	1,6	280	IP67	24,7	24,6	Ball Ø1,5	85	[6]	E	1732-45
D220	20	0 - 20	0 - 20,5	0,01	0,03	0,01	1,1	1,6	210	IP65	24,7	24,6	Ball Ø1,5	85	[6]	M	1732-45
C220S	20	0 - 20	0 - 20,5	0,01	0,03	0,01	1,1	1,6	280	IP67	24,7	24,6	Chisel R 0,4	85	[7]	E	1732-45
D220S	20	0 - 20	0 - 20,5	0,01	0,03	0,01	1,1	1,6	210	IP65	24,7	24,6	Chisel R 0,4	85	[7]	M	1732-45
C330	30	0 - 30	0 - 30,5	0,02	0,04	0,02	0,9	1,6	430	IP67	30	30	Ball Ø3	116	[6]	E	1732-51
C330S	30	0 - 30	0 - 30,5	0,02	0,04	0,02	0,9	1,6	430	IP67	30	30	Chisel R 0,75	116	[7]	E	1732-51

Measuring contacts

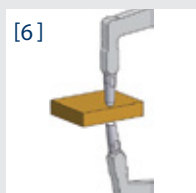

[6]
Ball Ø 1,5 mm
Ball Ø 3,0 mm

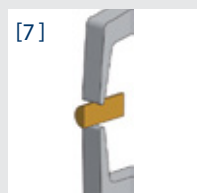

[7]
Chisel R 0,4 mm
Chisel R 0,75 mm



[23]
Ball Ø 5,0 mm



[24]
Needle Ø0,75 mm

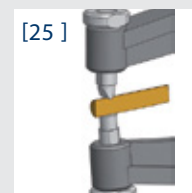

[25]
Chisel R 0,5 mm
Plane Ø 3,5 mm

Measuring capacity

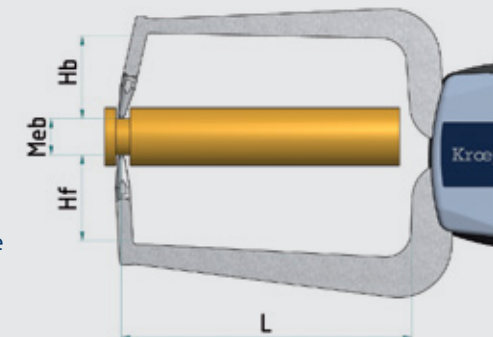

Hb Measuring contact movable
Hf Measuring contact fixed
L Measuring depth

External Measurement

Application range up to 200 mm

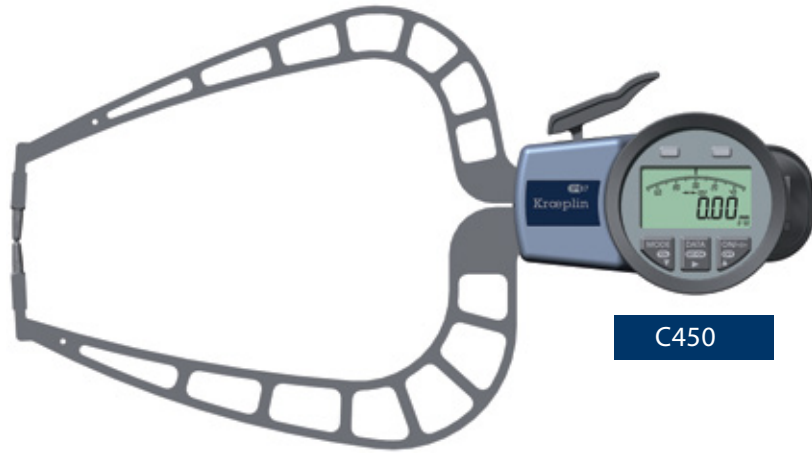

C450



C8100

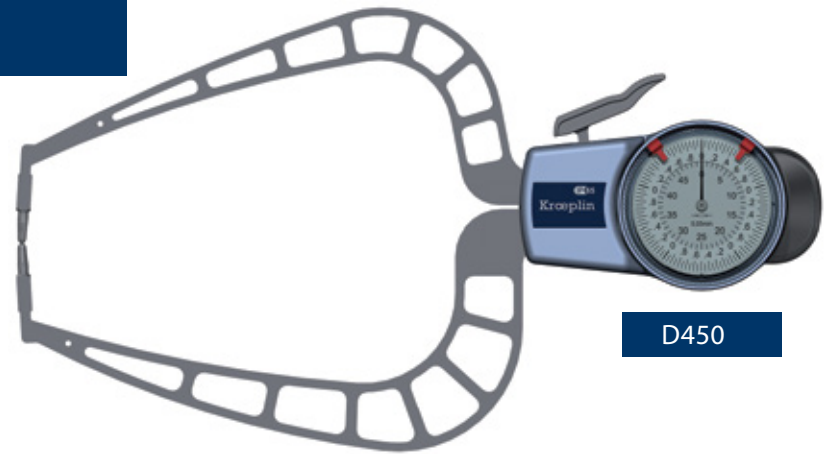

D450

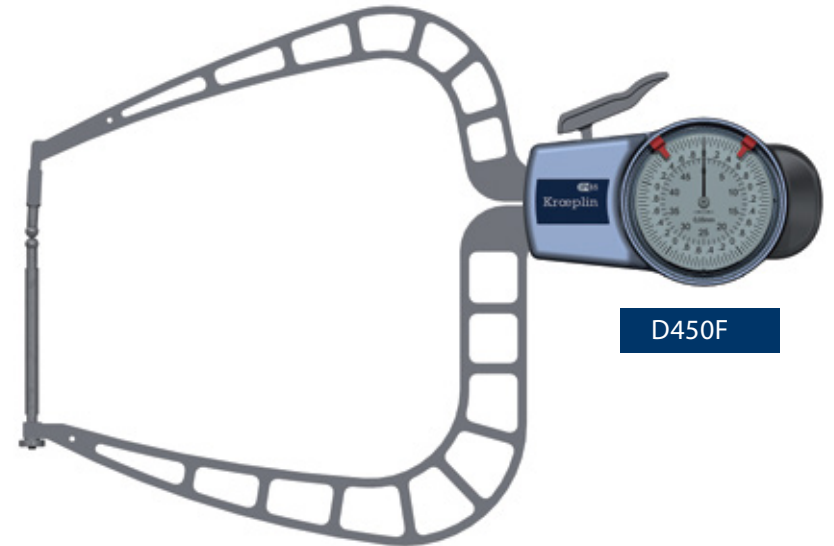

D450F



OD60100BJ

	Measuring span Mes	Measuring range Meb	Range of indication Azb	Scale interval Skw	Permissible errors G	Repeatability limit r	Measuring force min.	Measuring force max.	Weight	Protection class	Measuring contact movable Hb	Measuring contact fixed Hf	Type of measuring contact	Measuring depth L max.	Picture	Electronic E Mechanical M	Wooden box
Type	[mm]	[mm]	[mm]	[mm]	[mm]	[mm]	[N]	[N]	[g]		[mm]	[mm]	[mm]	[mm]			
C450	50	0 - 50	0 - 50,5	0,02	0,06	0,04	0,8	1,7	490	IP67	30	30	Ball Ø3	167	[6]	E	1732-51
D450	50	0 - 50	0 - 50,5	0,05	0,05	0,025	0,8	1,7	430	IP65	30	30	Ball Ø3	167	[6]	M	1732-51
C450S	50	0 - 50	0 - 50,5	0,02	0,06	0,04	0,8	1,7	490	IP67	30	30	Ball Ø3	167	[7]	E	1732-51
D450S	50	0 - 50	0 - 50,5	0,05	0,05	0,025	0,8	1,7	430	IP65	30	30	Ball Ø3	167	[7]	M	1732-51
C450B	50	0 - 50	0 - 50,5	0,02	0,08	0,06	0,8	1,7	510	IP67	72,6	30	Ball Ø5	167	[6]	E	HK
D450B	50	0 - 50	0 - 50,5	0,05	0,075	0,05	0,8	1,7	450	IP65	72,6	30	Ball Ø5	167	[6]	M	HK
C450F	50	0 - 50	0 - 50,5	0,02	0,08	0,06	0,8	1,7	510	IP67	30	72,6	Ball Ø5	167	[6]	E	HK
D450F	50	0 - 50	0 - 50,5	0,05	0,075	0,05	0,8	1,7	450	IP65	30	72,6	Ball Ø5	167	[6]	M	HK
C4100	50	50 - 100	49,5 - 100,5	0,02	0,08	0,06	0,8	1,7	510	IP67	30	23	Ball Ø3	167	[6]	E	HK
D4100	50	50 - 100	49,5 - 100,5	0,05	0,075	0,05	0,8	1,7	450	IP65	30	23	Ball Ø3	167	[6]	M	HK
C4150	50	100 - 150	99,5 - 150,5	0,02	0,08	0,06	0,8	1,7	530	IP67	30	23	Ball Ø3	167	[6]	E	HK
D4150	50	100 - 150	99,5 - 150,5	0,05	0,075	0,05	0,8	1,7	470	IP65	30	23	Ball Ø3	167	[6]	M	HK
C8100	100	0 -100	0 - 101	0,05	0,15	0,1	0,8	1,8	660	IP67	35	35	Ball Ø5	382	[16]	E	HK
D8100	100	0 -100	0 - 101	0,1	0,15	0,1	0,8	1,8	600	IP65	35	35	Ball Ø5	382	[16]	M	HK
OD60100	100	0 -100	0 - 101	0,1	0,3	0,15	1,5	2,5	1500	-	32	32	Ball Ø5	530	[16]	M	HK
OD60100BJ	100	0 -100	0 - 101	0,1	0,3	0,15	1,5	2,5	2300	-	32	132	Ball Ø5	530	[16]	M	HK
OD80200	200	0 - 200	0 - 201	0,2	0,4	0,2	1,0	2,0	2300	-	100	100	Hemisphere SR 20	725	[17]	M	HK

Measuring contacts

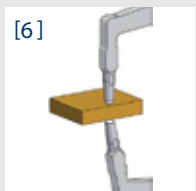

[6]
Ball Ø 2,0 mm
Ball Ø 3,0 mm
Ball Ø 5,0 mm



[7] Chisel R 0,75 mm



[16] Ball Ø 5,0 mm



[17] Hemisphere SR 20 mm

Measuring capacity

Hb Measuring contact movable
Hf Measuring contact fixed
L Measuring depth

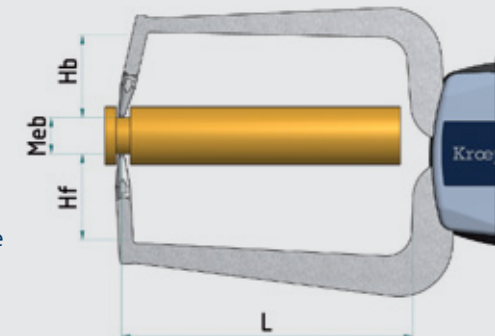

Tube wall measurement

Application range up to 100 mm



C1R10



D2R20



C3R30

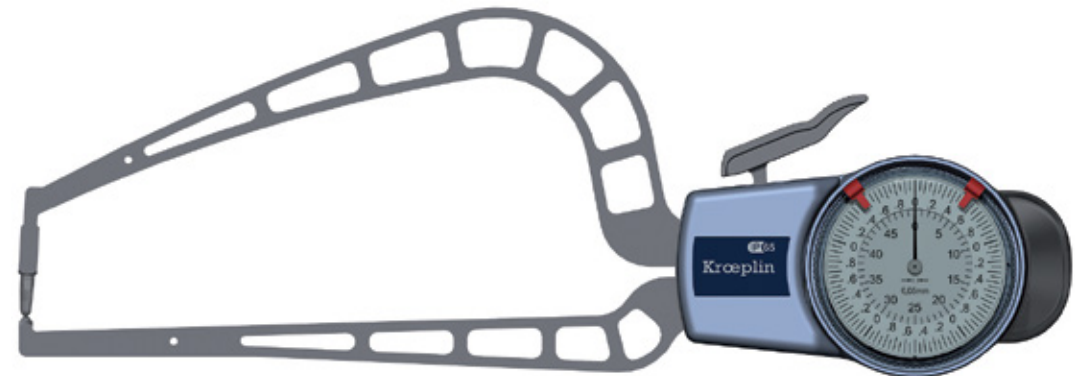

D4R50



POCO2R

	Measuring span Mes	Measuring range Meb	Range of indication Azb	Scale interval Skw	Permissible errors G	Repeatability limit r	Measuring force min.	Measuring force max.	Weight	Protection class	Type of measuring contact movable	Measuring contact movable Hb	Type of measuring contact	Measuring contact fixed Hf	bore diameter d min.	Measuring depth L max.	Picture	Mechanical M Electronic E	Wooden box
Type	[mm]	[mm]	[mm]	[mm]	[mm]	[mm]	[N]	[N]	[g]		[mm]	[mm]	[mm]	[mm]	[mm]	[mm]			
POCO 2R	10	0 - 10	0 - >10	0,1	0,1	0,05	0,3	1,3	40	-	Ball Ø 2,0	5,0	Hemisphere SR=0,5	0,8	3	25	[21]	M	1732-01
C1R10	10	0 - 10	0 - 10,5	0,005	0,015	0,005	0,8	1,2	235	IP67	Ball Ø 1,5	19,1	Ball Ø 1,5	0,9	3	35	[8]	E	1732-45
D1R10	10	0 - 10	0 - 10,5	0,005	0,015	0,005	0,8	1,2	165	IP65	Ball Ø 1,5	19,1	Ball Ø 1,5	0,9	3	35	[8]	M	1732-45
C1R10S	10	0 - 10	0 - 10,5	0,005	0,015	0,005	0,8	1,2	235	IP67	Chisel R = 0,4	18,8	Ball Ø 1,5	0,9	3	35	[9]	E	1732-45
D1R10S	10	0 - 10	0 - 10,5	0,005	0,015	0,005	0,8	1,2	165	IP65	Chisel R = 0,4	18,8	Ball Ø 1,5	0,9	3	35	[9]	M	1732-45
C2R20	20	0 - 20	0 - 20,5	0,01	0,03	0,01	1,1	1,6	270	IP67	Ball Ø 1,5	24,7	Ball Ø 1,5	2,5	9	80	[10]	E	1732-45
D2R20	20	0 - 20	0 - 20,5	0,01	0,03	0,01	1,1	1,6	200	IP65	Ball Ø 1,5	24,7	Ball Ø 1,5	2,5	9	80	[10]	M	1732-45
C2R20S	20	0 - 20	0 - 20,5	0,01	0,03	0,01	1,1	1,6	270	IP67	Chisel R = 0,4	24,7	Ball Ø 1,5	2,5	9	80	[11]	E	1732-45
D2R20S	20	0 - 20	0 - 20,5	0,01	0,03	0,01	1,1	1,6	200	IP65	Chisel R = 0,4	24,7	Ball Ø 1,5	2,5	9	80	[11]	M	1732-45
C3R30	30	0 - 30	0 - 30,5	0,02	0,04	0,02	0,9	1,6	410	IP67	Ball Ø 3	30	Ball Ø 3	4	10	116	[10]	E	1732-51
C3R30S	30	0 - 30	0 - 30,5	0,02	0,04	0,02	0,9	1,6	410	IP65	Chisel R = 0,75	30	Ball Ø 3	4	10	116	[11]	E	1732-51
C4R50	50	0 - 50	0 - 50,5	0,02	0,06	0,04	0,8	1,7	460	IP67	Ball Ø 3	30	Ball Ø 3	4,3	13	169	[10]	E	1732-51
D4R50	50	0 - 50	0 - 50,5	0,05	0,05	0,025	0,8	1,7	400	IP65	Ball Ø 3	30	Ball Ø 3	4,3	13	169	[10]	M	1732-51
C4R50S	50	0 - 50	0 - 50,5	0,02	0,06	0,04	0,8	1,7	460	IP67	Chisel R = 0,75	30	Ball Ø 3	4,3	13	169	[11]	E	1732-51
D4R50S	50	0 - 50	0 - 50,5	0,05	0,05	0,025	0,8	1,7	400	IP65	Chisel R = 0,75	30	Ball Ø 3	4,3	13	169	[11]	M	1732-51
C8R100	100	0 - 100	0 - 101	0,05	0,15	0,1	0,8	1,8	660	IP67	Ball Ø 5	35	Ball Ø 5	15	36	382	[15]	E	HK
D8R100	100	0 - 100	0 - 101	0,1	0,15	0,1	0,8	1,8	600	IP65	Ball Ø 5	35	Ball Ø 5	15	36	382	[15]	M	HK

Measuring contacts

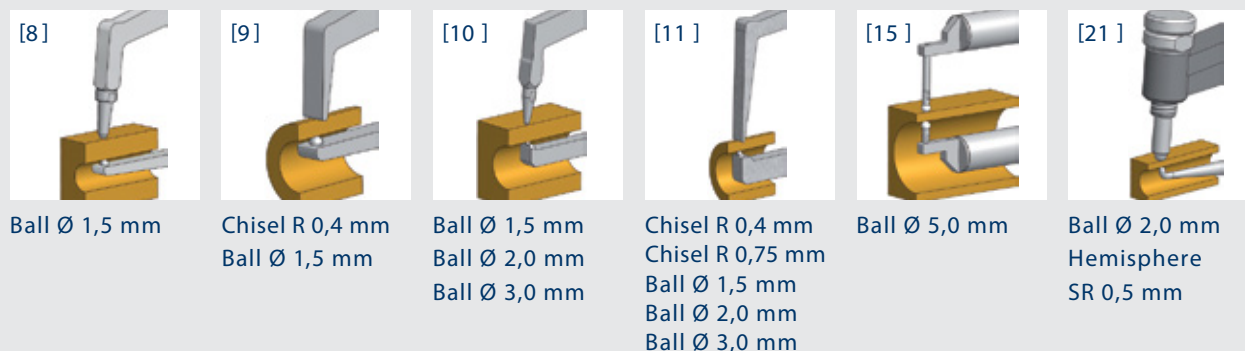

Measuring capacity

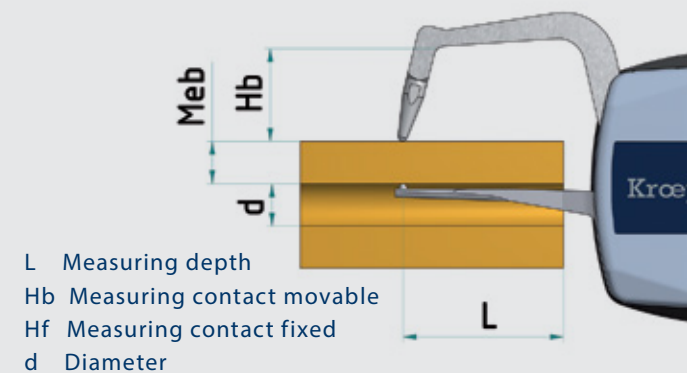

Measurement of foamed material and foils

Application range up to 100



C110T



D220T

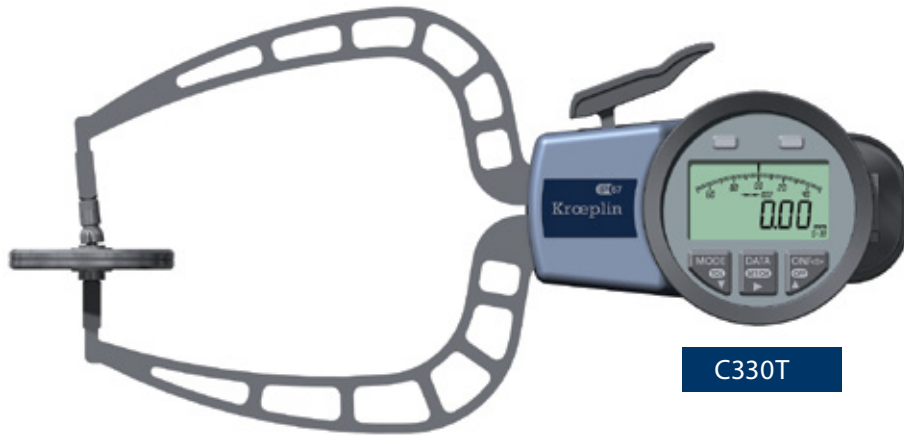

C330T

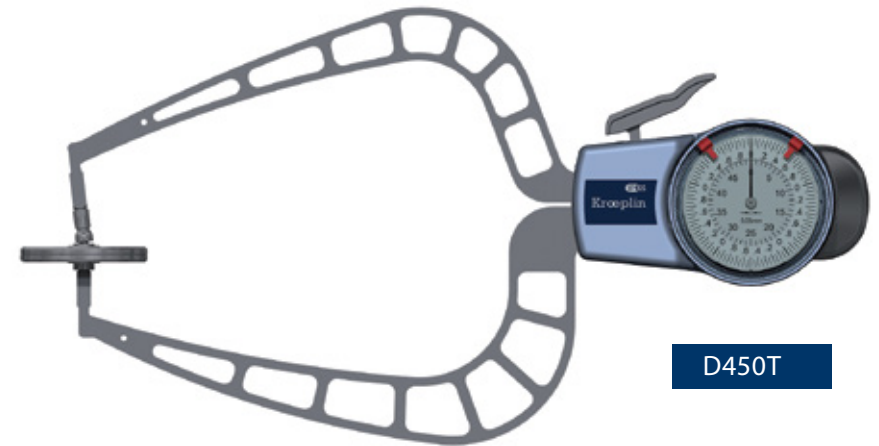

D450T



POCO2T

	Measuring span Mes	Measuring range Meb	Range of indication Azb	Scale interval Skw	Permissible errors G	Repeatability limit r	Measuring force min.	Measuring force max.	Weight	Protection class	Measuring contact movable Hb	Measuring contact fixed Hf	Type of measuring contact	Measuring depth L max.	Picture	Mechanical M Electronic E	Wooden box
Type	[mm]	[mm]	[mm]	[mm]	[mm]	[mm]	[N]	[N]	[g]		[mm]	[mm]	[mm]	[mm]			
POCO 2T	10	0 - 10	0 - >10	0,1	0,1	0,05	0,3	1,3	40	-	5,0	5,0	Flat Ø 10	36	[22]	M	1732-01
C110T	10	0 - 10	0 - 10,5	0,005	0,02	0,005	0,8	1,2	175	IP67	21,7	14,8	Flat Ø 6	35	[12]	E	1732-45
D110T	10	0 - 10	0 - 10,5	0,005	0,02	0,005	0,8	1,2	175	IP65	21,7	14,8	Flat Ø 6	35	[12]	M	1732-45
C220T	20	0 - 20	0 - 20,5	0,01	0,04	0,01	1,1	1,6	220	IP67	28,2	20,7	Flat Ø 10	85	[12]	E	1732-45
D220T	20	0 - 20	0 - 20,5	0,01	0,04	0,01	1,1	1,6	220	IP65	28,2	20,7	Flat Ø 10	85	[12]	M	1732-45
C330T	30	0 - 30	0 - 30,5	0,02	0,06	0,04	0,9	1,6	430	IP67	36	24	Flat Ø 50	116	[14]	E	1732-51
C450T	50	0 - 50	0 - 50,5	0,02	0,08	0,06	0,8	1,7	500	IP67	36	24	Flat Ø 50	167	[14]	E	1732-51
D450T	50	0 - 50	0 - 50,5	0,05	0,1	0,05	0,8	1,7	440	IP65	36	24	Flat Ø 50	167	[14]	M	1732-51
C8100T	100	0 -100	0 - 101	0,05	0,15	0,1	0,8	1,8	670	IP67	41	9	Flat Ø 50	382	[14]	E	HK
D8100T	100	0 -100	0 - 101	0,1	0,15	0,1	0,8	1,8	610	IP65	41	9	Flat Ø 50	382	[14]	M	HK
OD60100T	100	0 - 100	0 - 102	0,1	0,4	0,2	1,5	2,5	1700	-	46	26	Flat Ø 50	555	[14]	M	HK

Measuring contacts

[12]



Flat Ø 6 mm
Flat Ø 10 mm

[14]

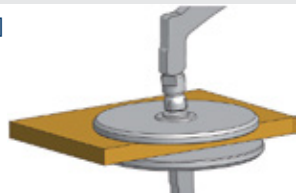

Flat Ø 50 mm

[22]

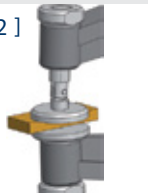

Flat Ø 10 mm

Measuring capacity

L Measuring depth
Hf Measuring contact fixed
Hb Measuring contact movable

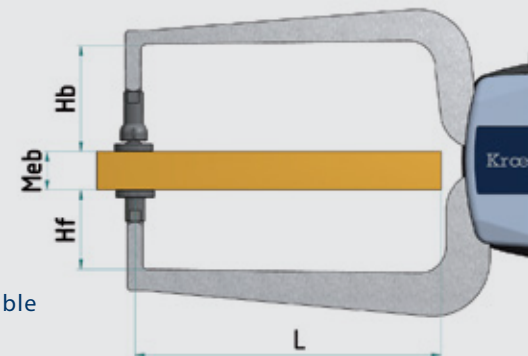

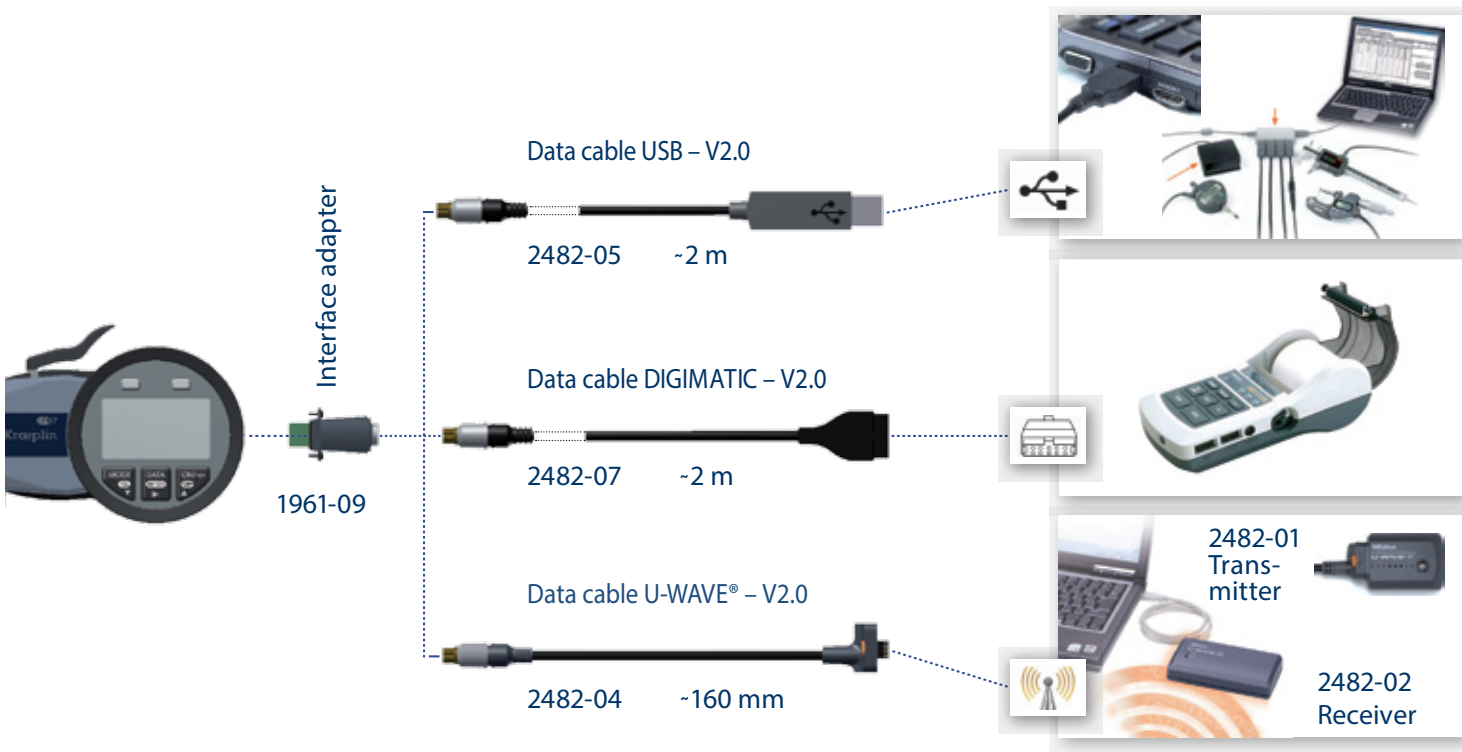

Interfaces may be upgraded on demand

Wooden boxes for all series
For order code please see
technical details
(HK = wooden box is
included in delivery)

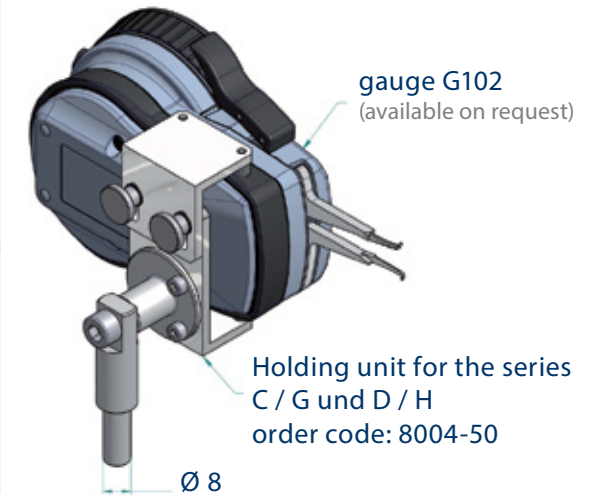

For measuring small parts the holding unit
enables the gauge (series C, G, D, H) to be
used with a measuring stand

Special Gauges

We are always searching for the best solution for your measuring problem, either mechanical or electronic. In order to enable us to find the solution together and to design your special gauge, please kindly send us a drawing of the object to be measured and indicate tolerance and measuring force, and if possible, send us a sample of the part to be measured. Full information in your enquiry enables us to put forward the optimum design solution for your application.

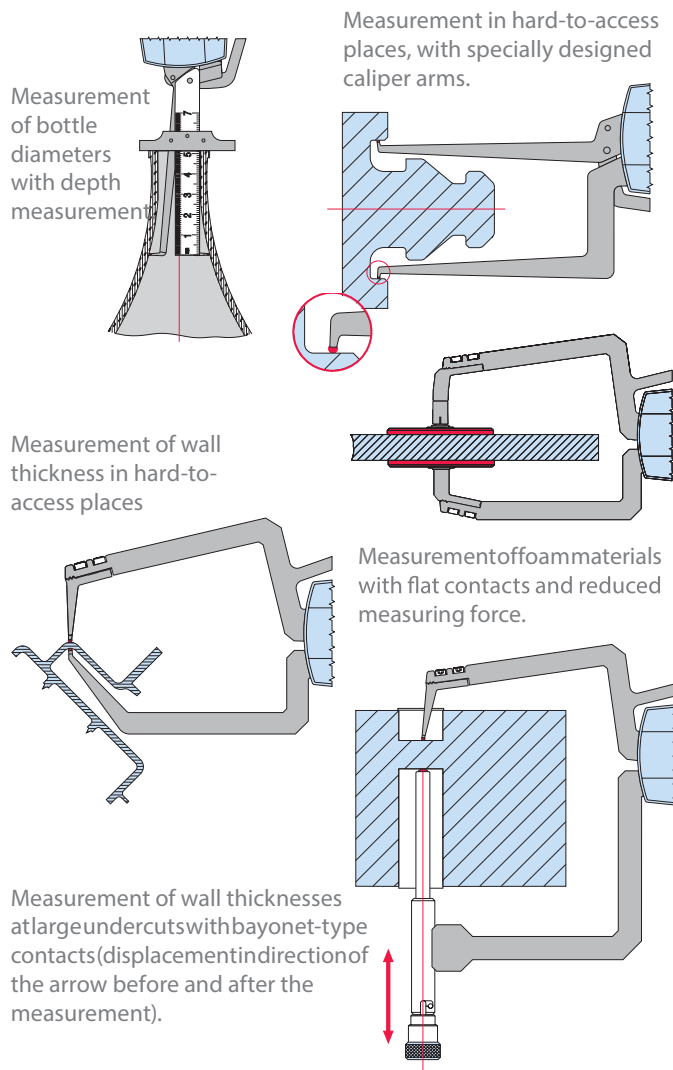

Definitions

Diagram of deviation

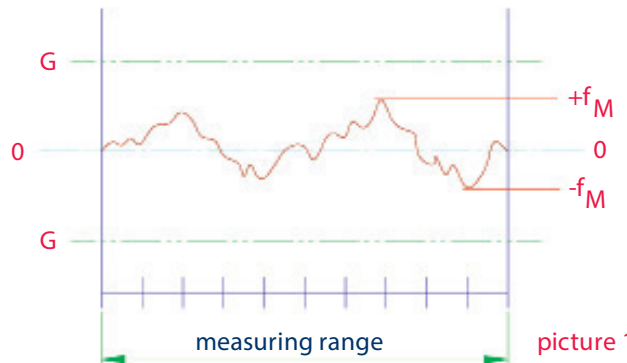

The individual diagram of deviation you can see in the certificate of quality which will be sent with every gauge.

Definitions

Terms of length test techniques see DIN 2257 part 1 and part 2 and International Vocabulary of Basic and General Terms in Metrology.

Foundations

This instruction follows approximately the checking instructions of the German standard DIN 878 for dial gauges and the checking instructions for caliper gauges according to VDI/VDE/DGQ 2618, page 13. The gauges are referred to as gauges with absolute measurement and adjustable zero point.

Range of indication Azb

The range of indication is the range between the highest and the lowest indication.

Measuring range Meb

The measuring range of a gauge represents the range of measuring values in which given error limits must not be exceeded.

Measuring span Mes

The measuring span is the difference between starting value and final value of the measuring range.

Scale interval Skw

The scale interval is the modification of the value of a measured variable that causes the modification of the indication by one interval. The scale interval is indicated in the unity of the measured variable.

Deviation in the measuring range f_M

The deviation in the measuring range f_M represents the distance of ordinates between the highest and the lowest position in the deviation diagram, when the movable caliper arm closes. The tolerance field G for f_M is symmetrically positioned to the zero line.

Repeat precision f_w

The repeat precision f_w is a characteristic value for deviations of the measured quantity within the measuring range in the same motion direction of the movable caliper arm (usually $n=5$). This margin of error is designated as repeat limit r .

Measuring force F_{min}, F_{max}

When the caliper arm closes, the measuring force F_{max} bzw. F_{min} is determined at the top of the movable caliper arm. The gauge must be held in vertical position ≥ 200 mm



Kroeplin
Längenmesstechnik

שטרנג אבי
ציוד טכני בע"מ

יבואנים בלעדיים בישראל
שירות תיקון עם חלפים מקוריים

רח' המרכבה 19,

ת.ד. 1730

א.ת. חולון 5811701

טל: 03-5599222

פקס: 03-5598777

דוא"ל: office@streng.co.il

אתר: www.streng.co.il

Application area

- n Mechanical engineering
- n Automobile industry
- n Aerospace industry
- n Wire manufacturers:
Diameter determination of continuous wires
- n Glass industry: Measurement of wall thickness
in hard-to-access places
- n Dental laboratories: Measurement of tooth
crown thicknesses
- n Aerosol and packaging industry:
Measurement of aerosol cans
- n Foundries: Measurement of cast wall thicknesses
- n Key manufacturers: Measurement of milled
notches of keys
- n Foamed material industry: Measurements
of foamed material thicknesses
- n Tubemanufacturers: Internal and external measurements,
also of extremely wide tubes
- n Ceramic industry: Safe and simple determination
of contraction due to baking and drying.
- n Gun clubs: Checking of the admissible thickness
of shooting jackets
- n Medical institutes: Skin fold and joint measurement in
human and animal subjects
- n Special designs: Your measuring task is among them