

HITS

TESA



פתרונות מדידה
www.streng.co.il • 03-5599222.70

שטרנג אבי
ציוד טכני בע"מ



Digital Calipers
the BEST DEALS



TESA-CAL IP67
150 mm
0 ÷ 150 mm – 0 ÷ 6 in

00530300

₪ 596



Sho P-CAL
150 mm
0 ÷ 150 mm – 0 ÷ 6 in

00530090

₪ 395



Calipers – Everyday Essentials

A full range of TESA calipers offering different readings

- Linear scale with vernier
- Circular scale with dial gauge
- Numerical scale

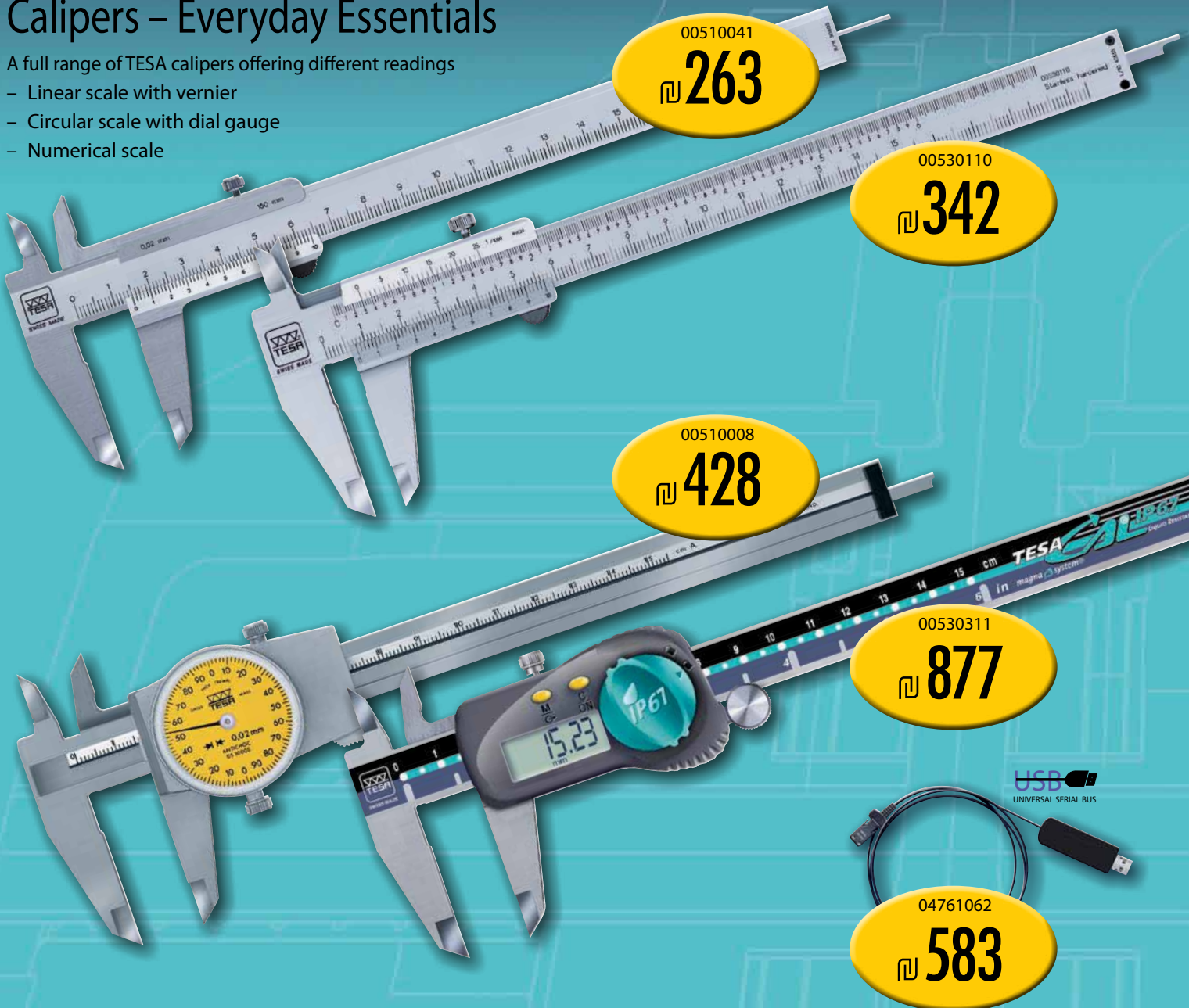

Order number	Description	Measuring range, mm	in	מחיר מבצע בש"ח
00510041	SWISSCAL 2 with vernier reading, 0,02 mm	0 ÷ 150	–	263
00530110	Model with vernier reading, 0,02 mm / 0.001 in	0 ÷ 150	0 ÷ 6	342
00530111	Model with vernier reading, 0,02 mm / 0.001 in	0 ÷ 200	0 ÷ 8	582
00530112	Model with vernier reading, 0,02 mm / 0.001 in	0 ÷ 300	0 ÷ 12	1168
00510008	CCMA dial caliper, 2 mm/revolution	0 ÷ 150	–	428
00510045	CCMA dial caliper, 2 mm/revolution	0 ÷ 200	–	838
00510046	CCMA dial caliper, 2 mm/revolution	0 ÷ 300	–	1189
00530311	TESA - CAL IP67 with digital output	0 ÷ 150	0 ÷ 6	877
00530312	TESA - CAL IP67 with digital output	0 ÷ 200	0 ÷ 8	1038
00530313	TESA - CAL IP67 with digital output	0 ÷ 300	0 ÷ 12	1548
04761062*	USB cable for TESA-CAL IP67 with digital output (L = 2 m)			583

*A DEMO version of DATA-Direct for value acquisition (04981001) is available on the website www.tesabs.ch



TRIO-O-BoR



Internal Micrometers – Specific to TESA

Custom made measuring bolts for through holes, blind bores and slots (must be specified when ordering).

Order number	Measuring range, mm	Numerical interval, mm	Max.perm. error, μm	מחיר מבצע בש"ח
00910005	15 ÷ 20	0,002	4	3948
00910006	20 ÷ 25	0,002	4	3997
00910007	25 ÷ 30	0,002	4	4048
00910405	30 ÷ 40	0,002	4	4593
00910406	40 ÷ 50	0,002	4	4712
00910407	50 ÷ 60	0,002	5	4834
00910705	60 ÷ 70	0,002	5	5188
00910706	70 ÷ 80	0,002	5	5266
00910707	80 ÷ 90	0,002	5	5329
00911105	90 ÷ 100	0,002	5	5614
00911106	100 ÷ 110	0,002	6	5693
00911107	110 ÷ 120	0,002	6	5745

Measurement capabilities*

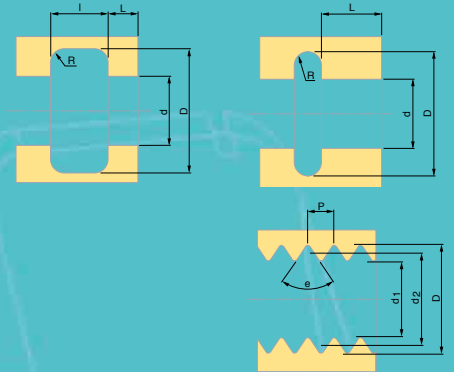

*Measuring bolts with special design are supplied with additional charge

INTALOMETER

The measuring bolts are specially arranged (90°- 135°- 135°) to allow for the determination of form errors.

Order number	Measuring range, mm	Scale interval, mm	Max.perm. error, μm	מחיר מבצע בש"ח
078112364	20 ÷ 25	0,002	3	3788
078112365	25 ÷ 30	0,002	3	3788
078112366	30 ÷ 35	0,002	3	3788
078112367	35 ÷ 40	0,002	3	3788
078112368	40 ÷ 45	0,002	4	4257
078112369	45 ÷ 50	0,002	4	4257
078112370	50 ÷ 60	0,002	4	4651
078112371	60 ÷ 70	0,002	4	4651
078112372	70 ÷ 85	0,002	4	5078
078112373	85 ÷ 100	0,002	4	5078

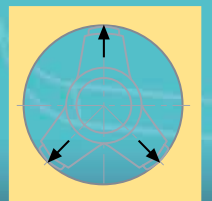



DIGICO

TESA DIGICo Electronic Indicators with Large LC Display for Easy Reading

4 models for definite applications

- DIGICo405 for common comparative measurement
- DIGICo505 for high-precision measurement
- DIGICo605 for dynamic Min/Max measurement
- DIGICo705 for bore measurement (requires the use of a bore gauge)



01930240

₪ 929



01930258

₪ 1863



01639009+01610200+01640000

₪ 4352

Measuring stand comes without indicator

Order number	Description	Measuring span, mm	Resolution, mm	מחיר מבצע בש"ח
01930240	DIGICO 405 with rotatable dial and tolerance	12,5	0,01	929
01930250	DIGICO 505 with rotatable dial and tolerances	12,5	0,001	1546
01930256	DIGICO 605 with Min/Max measuring mode	12,5	0,001	1793
01930258	DIGICO 705 for internal measurement	12,5	0,001	1863
04761062	USB- Cable			583
01639009	UA30 measuring stand			1736
01610200	UK20 measuring arm for UA30 stand			2186
01640000	Depth stop plate for UA30 stand			428





NEW



TESA INo TEST for Large Dimensions with one DIGICo 705

Modifications for special applications can be quoted and manufactured on request, e.g. INOTEST with digital display.

Order number	Description	מחיר מבצע בש"ח
S11010611	INOTEST numerical*	21888
01111900	INOTEST analogue*	20192

*Measuring range: inside 275 ÷ 1025 mm, outside 250 ÷ 1010 mm.

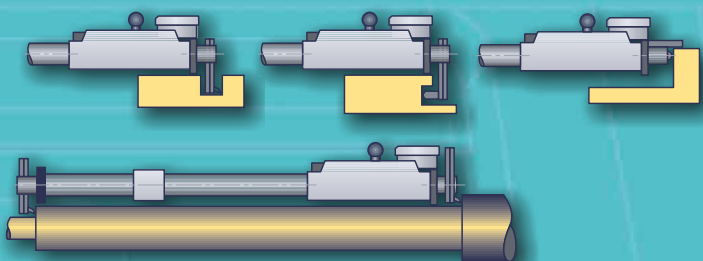

S11010611
₪ 21,888

מערכת למדידת קטרים בטווחים גדולים בהתאם לדרישת הלקוח

Dial Indicators (lever-type)

3 different dial positions for specific measurements.



01639023+01811000
₪ 1827

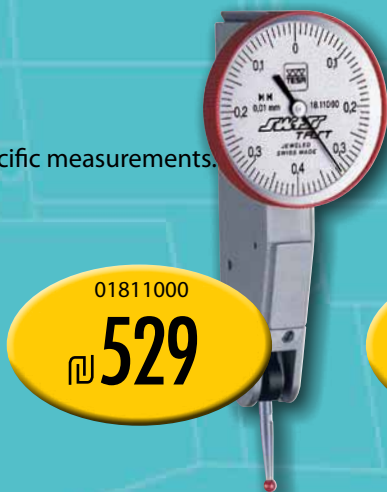

01811000
₪ 529



01810204
₪ 994



01810011
₪ 939

Order number	Description	Measuring span, mm	Scale interval, mm	מחיר מבצע בש"ח
01811000	SWISSTAST	0,8	0,01	529
01810204	TESAST, perpendicular	0,8	0,01	994
01810304	TESAST, perpendicular	0,2	0,002	1249
01810011	TESAST, lateral	0,8	0,01	939
01810013	TESAST, lateral	0,2	0,002	1053
01639023	Magnetic support for a dial indicator			1298





HITS

שטרנג אבי
צ'יוד טכני בע"מ



TESA-hite

TESA Micro-hite Plus M



00730044
₪ 21,698



00730043
₪ 16,998



00730063+00760221
₪ 27,998

height Gauges

TESA height gauges are available in manual or motorised versions to suit all customer's needs.



Order number	Description	Measuring span, mm	Max. perm. error, μm	מחיר מבצע בש"ח
00730043	TESA-HITE 400	415	(2,5 + 4·L) μm , L in m	16,998
00730044	TESA-HITE 400	715	(2,5 + 4·L) μm , L in m	21,698
00730063	MICRO-HITE plus M 350	365	(2 + 1,5·L) μm , L in m	24,100
00730064	MICRO-HITE plus M 600	615	(2 + 1,5·L) μm , L in m	26,497
00730065	MICRO-HITE plus M 900	920	(2 + 1,5·L) μm , L in m	43,876

- המחירים לא כוללים מע"מ
- המבצע בתוקף לזמן מוגבל ועד גמר המלאי

טל. 03-5599222
www.streng.co.il

שטרנג אבי
צ'יוד טכני בע"מ





MuST hAVE

Perpendicularity and straightness measurement



00760140
₪ 4839

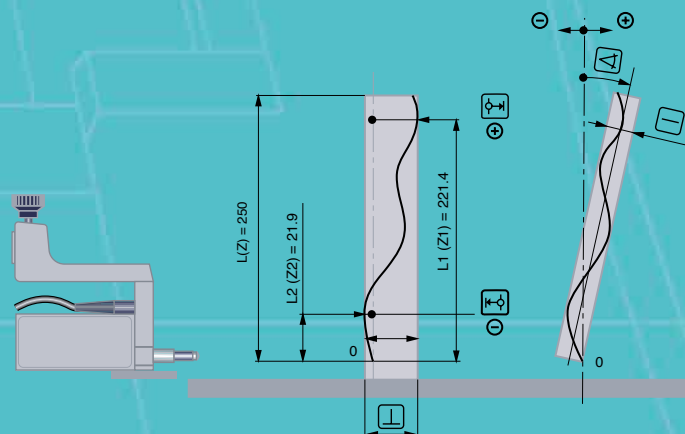
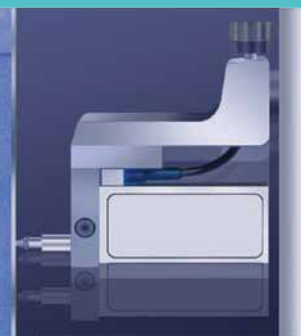

00730064+00760221
₪ 30,395

00730065+00760221
₪ 47,774

Extensive accessory set



00760148
₪ 7824

Order Number	Description	מחיר מבצע בש"ח
00760220	POWER PANEL with printer	5038
00760221	POWER PANEL without printer	3898
00760140	IG13 probe for MICRO-HITE plus M	4839
00760148	Extensive accessory set	7824





HITS

NEW

uSB Probe Interface

Simple and direct connection of standard probes to a PC over the USB port.

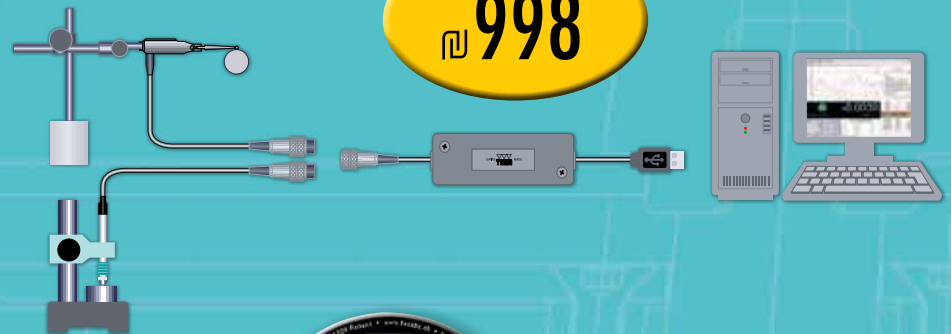
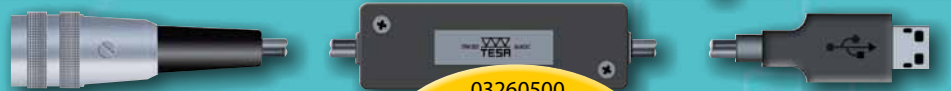
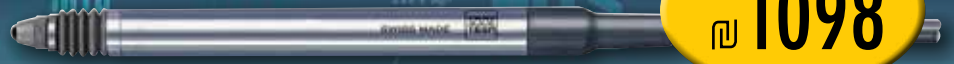

Order number	Description	Measuring span, mm	Precision (MPE), μm	מחיר מבצע בש"ח
03260500	USB adapter for GT21 or GT31 standard axial probes	± 2	$0,3\% \pm 0,1 \mu\text{m}$	998
03260501	USB adapter for GT61 axial probes with extended range	± 5	$0,3\% \pm 0,1 \mu\text{m}$	998
03210802	GT31 lever probe	$\pm 0,3$	$(0,2 + 50 \cdot L^2) \mu\text{m}$, L in mm	3149
03210904	GT21 axial probe	± 2	$(0,2 + 3 \cdot L^3) \mu\text{m}$, L in mm	1098
03230041	GT61 axial probe	± 5	$(1 + 4 \cdot L) \mu\text{m}$, L in mm	1798
01639007	Small magnetic support for GT31 lever probe			496
04981001	DATA-Direct software for data acquisition			2233
04981002	STAT-Express software for statistical value processing			4836



פתרונות מדידה



שטרנג אבי
צ'יוד טכני בע"מ



משרדים, מכירות, אולם תצוגה, מרכז שירות תיקונים וכיולים

רח' המרכבה 19, ת.ד. 1730, א.ת. חולון 58117

www.streng.co.il • office@streng.co.il

טל . 03-5599222 • פקס . 03-5598777

• המחירים לא כוללים מע"מ • המבצע בתוקף לזמן מוגבל ועד גמר המלאי

HEXAGON METROLOGY