

OD plug gauge in open design
Special designs
Accessories

OD plug gauge for various
bore diameters
Cross sleeve
Cross sleeve with runners

OD plug gauge

for bores and internal profiles from dia. 2,5 mm

Oskar Schwenk GmbH & Co.
Esslinger Straße 84
70736 Fellbach

300

Telefon 07 11 / 57550-0
Telefax 07 11 / 57550-11
E-mail Oskar.Schwenk@t-online.de



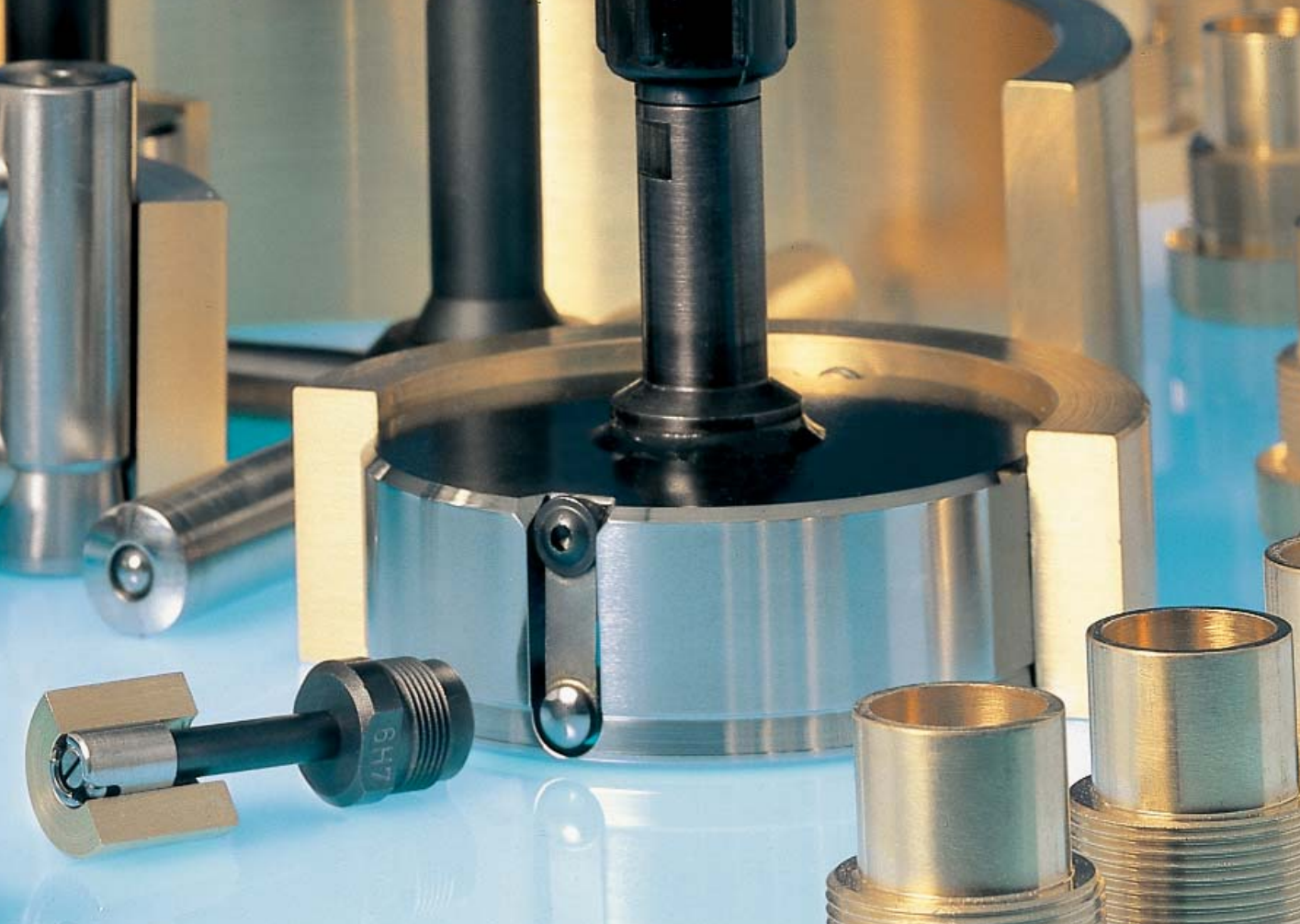

Applications

The OD plug gauge is a robust and easy to use comparator measuring instrument, which is conceived for the series control of bores.

- The OD plug gauge meets the following requirements:
- easy handling
- quick measurement
- maximal measurement certainty
- robust and reliable measuring instrument

The OD plug gauge is ideally suited wherever it is necessary to get a quick and reliable measuring result:

- direct on the production machine
- in the incoming or final inspection
- in the room for precision measuring

The OD plug gauge is the ideal replacement for usual plug gauges, whenever the statement „good / bad“ is not satisfying enough. Furthermore, it is possible to use it either manually, or as a part of a fully automatic measuring station.

General Remarks

The OD plug gauge is a mechanical two-point contact comparator measuring instrument suited for manual or automatic measurement.

Each measuring instrument is specially tailored to suit a specific diameter and the corresponding tolerance.

The OD plug gauge serves for the measurement of bores with a diameter from 2,5 up to 500 mm, as well as their deviations in form, without searching for the reversal point on the indicating unit.

For the indication of the measuring value, precision indicators, mechanical or electronic dial gauges or electronic probes can be used.

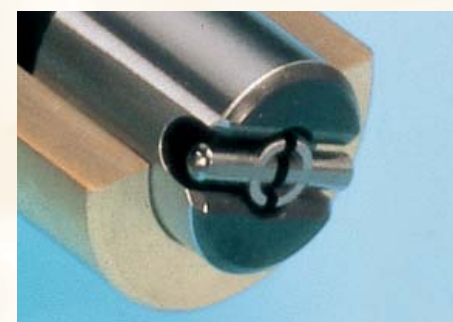

Functions

Centring

The surface line of the OD sleeve centres the measuring instrument automatically in the bore. The length of the sleeve is chosen in accordance with the diameter, in order to obtain an optimal alignment of the gauge in the bore.



Splitprobe with measuring needle



Transfer of the measuring travel

An expanding probe with measuring contacts is located inside the plug gauge. This probe is split open by the wedge-shaped measuring needle made of wear-resisting tungsten carbide.

Through the wedge of the measuring needle, the radial movement of the measuring contacts is transferred free of backlash to the unit used for the length measurement. The precisely grinded wedge of the measuring needle guarantees an excellent linearity.

Construction

The OD system consists of the following components:

- indicating unit (dial gauge, precision indicator, etc...)
- holder with thread connection M 11 x 0,75 - suitable for all OD measuring sleeves
- exchangeable measuring sleeves made of hardened and grinded tool steel, hard chromed on request, adjusted to each bore diameter with tolerance, with an integrated expanding probe and wedge-shaped needle
- options, for example depth stop, measuring depth extension, etc...
- reference, for example setting ring, reference piece, etc....

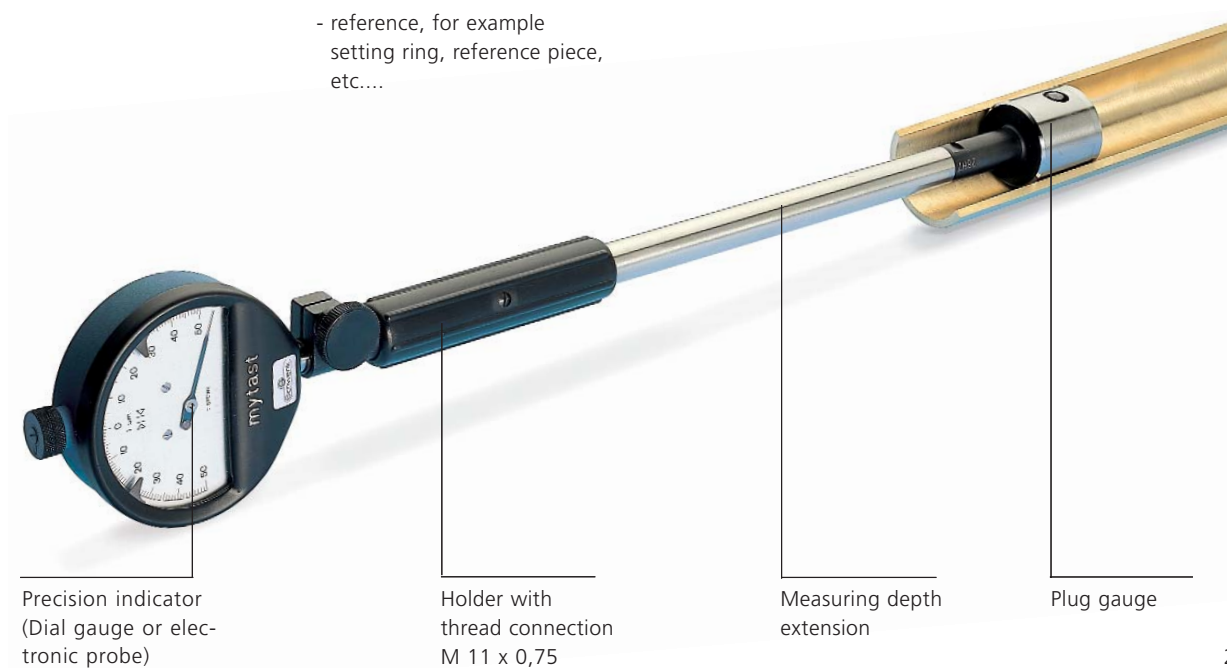

Precision indicator (Dial gauge or electronic probe)

Holder with thread connection M 11 x 0,75

Measuring depth extension

Plug gauge

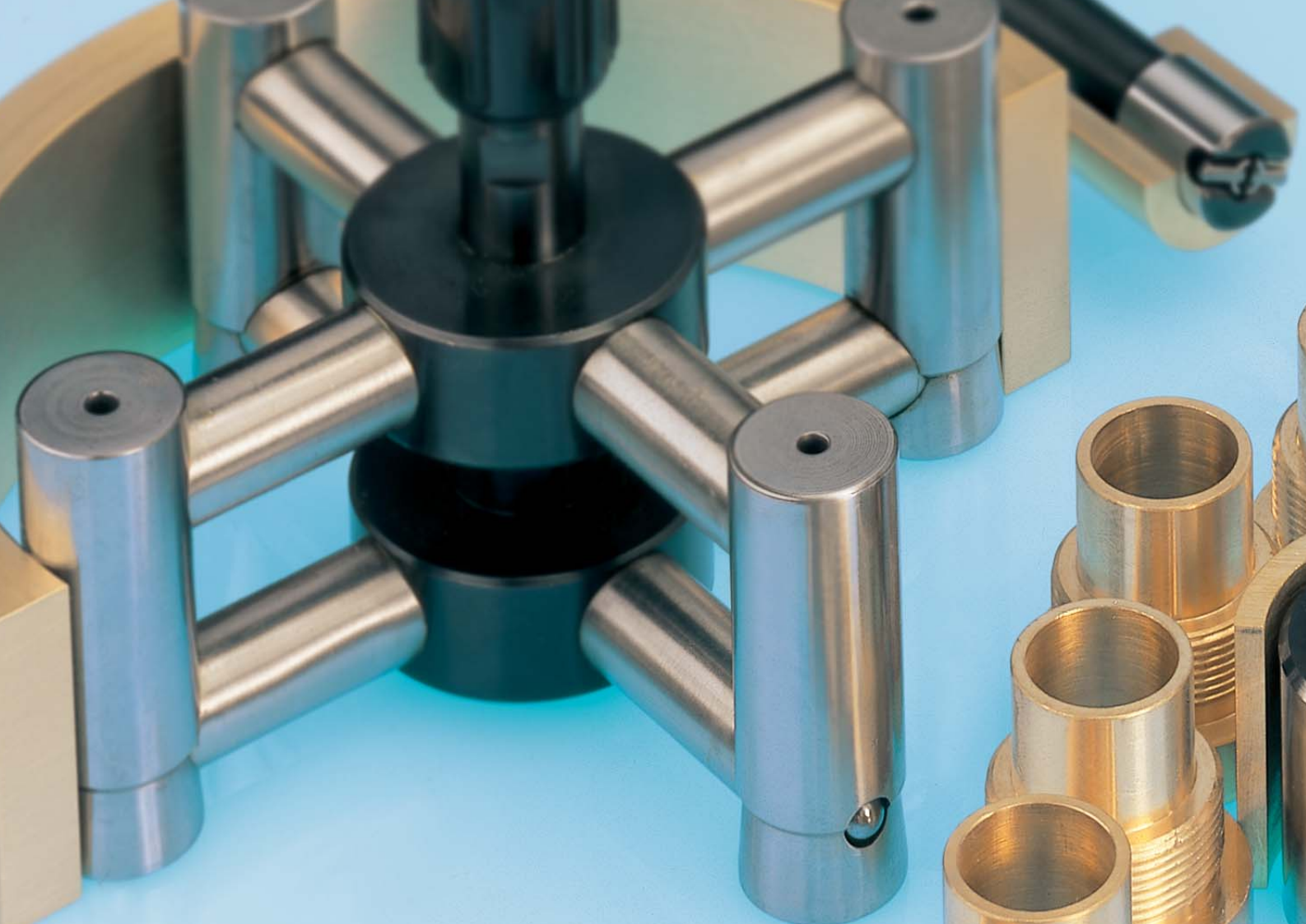

Cross sleeve for dia. 130-500 mm for blind bores or short centring shoulders



Cross sleeve with runners for dia. 130-500 mm for deep bores or through bores, alignment in the bore is made through the 4 runners



OD plug gauge for various bore diameters

Advantages

Highest precision

The precision of a comparator gauge is shown clearly with the repeatability. For the OD plug gauge this is max. 0,5 to 1 µm (for standard design up to diameter 130 mm).

Easy handling

The OD plug gauge enables the measurement without searching for the reversal point on the indicating unit and is therefore also suitable for unskilled users.

High measuring certainty

Since the OD sleeve, which is exactly tailored for a specific measuring situation, centres and guides the measuring instrument in the bore, the influence of the user on the measuring result is minimised.

Fast measuring process

A stationary measuring value is obtained immediately when entering the bore to be measured. This enables a large number of measurements within the shortest period of time.

High flexibility

All the OD measuring sleeves and the corresponding holders have a thread connection M 11 x 0,75.

Therefore it is possible to choose any combination required; a quick adjustment to any measuring task is guaranteed.

Accessories, like for example an angle piece or measuring depth extensions, can be assembled without any problem.



No tilting

The unique insertion chamber of the measuring sleeve prevents any tilting when entering the measuring instrument in the bore.

High service life/robustness

The robust OD measuring sleeves are made of hardened tool steel, grinded to the required diameter and are suitable for the use in the production.

As an option, hard chromed measuring sleeves are available, which offer more protection against wear and corrosion.

The measuring contacts are as a standard fitted with tungsten carbide balls. The wedge-shaped measuring needle is generally made of tungsten carbide.

Through the modular system, the OD system enables a very easy maintenance.

Easy setting

As setting references, setting rings are often used in practice; the use of master pieces or external micrometers is also possible.

Cross sleeve with runners

From diameter 130 mm, SCHWENK offers the so-called cross sleeve or cross sleeve with runners. In opposition to the conventional full round OD sleeve, the cross sleeve (with runners) presents advantages regarding the weight and the handling when measuring large diameters.





„h“ = 10 mm

For through bores. Bore diameters can already be measured from the very beginning of the bore.

„h“ = 1 or 1,5 mm

Especially for blind bores or bores with a shoulder.

Basic designs

The difference between the three OD basic designs which are mainly used in practice is the type of bore to be measured. The distance between the measuring axis and the lower edge of the measuring sleeve is decisive therein. The appropriate term for this is the so-called „front distance“. The three situations are:

A table with the selection criteria for the three OD basic designs is to be found on the reverse of this leaflet.

„h“ = standard

This design enables the most universal measurements.

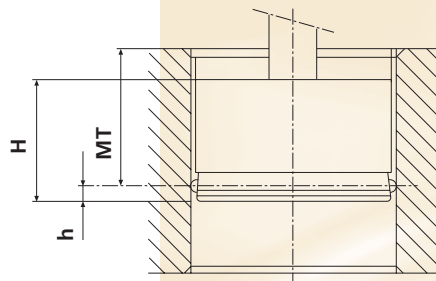

OD plug gauge in open design

Special OD plug gauge with 2 measuring axes (from dia. 30 mm)



Depth stop for OD plug gauges



Holder F, holders in various length

Special designs

The OD system offers many variation possibilities, in order to adapt the measuring instrument optimally to the measuring problem. Here are some examples:

- enlarged or reduced measuring travel
- sleeve with a specific under-size under the lower tolerance
- special material for the measuring contacts, for example synthetic, ceramic, ruby, hard chromed, etc...
- specific shape for the measuring contacts, for example mushroom-shaped with enlarged radius, wedge-shaped contacts, etc...
- measuring sleeve surface hard chromed or coated wear-resisting with „Dynamant“
- specific insertion chamfer, for example for automatic measurements
- plug gauge in 3-point design for polygonal workpieces
- other special solutions, for example for the measurement of tapers, with several measuring axes in one measuring sleeve, for plane parallel distances, for the measurement of grooves or profiles, etc...
- inspection certificate available on request for all OD measuring sleeves.

Accessories

Holders

- in different lengths
- with clamping shaft 8 h6 or 3/8"
- for electronic probes, etc...
- with retraction to take off the measuring force

Measuring depth extensions

- out of Invar tubes, available from diameter 4 mm

Angle piece

- for awkwardly positioned bores

Depth stops

- for specific measuring depths and for a higher measuring certainty

Stand

- for stationary measurements

Floating holder

- suitable for automatic measuring stations and stands

Detailed technical descriptions about the OD plug gauge programme are shown in the documentation 300T and are available on request.

We would be pleased to solve your measuring problems!



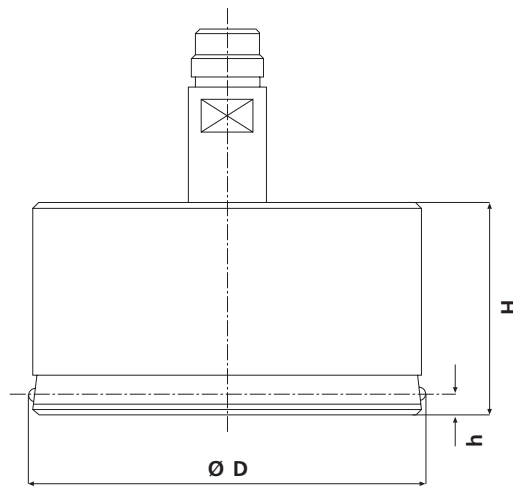

Technical data of the
OD measuring sleeves

Range of application	mm	mm	mm	mm	mm	mm	mm
from	2,5	6,1	16,1	30,1	45,1	130,1	300,1
to	6	16	30	45	130	300	500
Travel s	0,15	0,2	0,2	0,2	0,2	0,2	0,3
Front distance h	1,5/6	2,5 /10	2,5 /10	2,5 /10	3,5 /10	6' /18 ²	9' /25 ²
Front distance h (blind bores)	1	1	1,2	1,2	1,2	3'	4'
Length of sleeve H	10	15	20	33	33	55	75
Contact point force N	0,5-1 N						
Repeatability μm^*	0,5	0,5	0,5	0,5	1	2	3
Thread G	M11						

Notice:

¹Cross sleeve (protected by patent design no 9404093)

²Cross sleeve with runners (protected by patent design no 9404093)

*in a setting ring

